

## DOCUMENT RESUME

ED 063 513

VT 015 722

TITLE Yugoslavia--The Education, Training and Functions of Technicians. Scientific and Technical Personnel.

INSTITUTION Organisation for Economic Cooperation and Development, Paris (France). Directorate for Scientific Affairs.

PUB DATE Oct 67

NOTE 85p.

EDRS PRICE MF-\$0.65 HC-\$3.29

DESCRIPTORS Articulation (Program); Economic Development; \*Foreign Countries; Job Analysis; \*Job Training; Manpower Development; \*Manpower Utilization; \*National Surveys; Tables (Data); Teacher Education; \*Technical Education; Vocational Education

IDENTIFIERS Yugoslavia

## ABSTRACT

To identify problems regarding economic development, the Committee for Scientific and Technical Personnel conducted an educational and occupational survey of each member country of the Organisation for Economic Cooperation and Development (OECD). The specific purpose of the surveys was to gather comparative data on the training and utilization of technicians in each member country. Major sections of each survey are: (1) The Structure of the Educational System, (2) Training of Technicians and Other Technical Manpower, and (3) Functions of Technicians. Related surveys for each of the following countries, Canada, Denmark, Spain, France, Netherlands, Switzerland, United Kingdom, Portugal, and Italy, are available in this issue as VT 015 716-VT 015 721 and VT 015 723-VT 015 725 respectively. (JS)

ED 063513



DOCUMENT

THE EDUCATION, TRAINING AND FUNCTIONS  
OF TECHNICIANS

YUGOSLAVIA

VT015722

DIRECTORATE FOR SCIENTIFIC AFFAIRS

ORGANISATION FOR ECONOMIC CO-OPERATION AND DEVELOPMENT

# SCIENTIFIC AND TECHNICAL PERSONNEL

U.S. DEPARTMENT OF HEALTH,  
EDUCATION & WELFARE  
OFFICE OF EDUCATION  
THIS DOCUMENT HAS BEEN REPRO-  
DUCED EXACTLY AS RECEIVED FROM  
THE PERSON OR ORGANIZATION ORIG-  
INATING IT. POINTS OF VIEW OR OPIN-  
IONS STATED DO NOT NECESSARILY  
REPRESENT OFFICIAL OFFICE OF EDU-  
CATION POSITION OR POLICY.

## THE EDUCATION, TRAINING AND FUNCTIONS OF TECHNICIANS

# YUGOSLAVIA

**DIRECTORATE FOR SCIENTIFIC AFFAIRS**

**ORGANISATION FOR ECONOMIC CO-OPERATION AND DEVELOPMENT**

2, rue André-Pascal, Paris-16<sup>e</sup>

CONTENTS

PREFACE . . . . . 9

Part One

The Structure of the Educational System

I. General Data - The Place of Technical Education in the Educational System . . . . . 11  
II. Vocational Orientation and Guidance . . . . . 13  
III. Authorities in Charge of Education - Co-ordinating and Planning Mechanisms . . . . . 14

Part Two

Training of Technicians and Other Technical Manpower

IV. Definition and Grading of the Technician Standardized Qualifications . 17  
    (a) Content of courses . . . . . 17  
    (b) Final examinations - diplomas and certificates . . . . . 18  
V. Lower-level Technician Courses within the "Formal" Educational System . . . . . 18

VI. Upper-level Technician Courses within the "Formal" Educational System . . . . .	19
VII. Vocational Courses at Craftsman Level within the Educational System . . . . .	20
(a) Schools for practical training . . . . .	20
(b) Apprenticeship schools . . . . .	20
VIII. Technical Courses at University Level . . . . .	21
IX. Technical Teaching Staff . . . . .	22
(a) Recruitment - Pupil/teacher ratios . . . . .	22
(b) Training courses for technical teachers . . . . .	22
(c) Status and salaries of technical teachers . . . . .	22
X. Training outside the Formal System . . . . .	25
(a) Apprenticeship training . . . . .	25
(b) Courses held by non-governmental organizations . . . . .	25
(c) Adult education . . . . .	26
(d) Correspondence courses . . . . .	26
XI. Commercial Education . . . . .	26
XII. Agricultural Education . . . . .	26
XIII. Hotel, Catering and Tourism Courses . . . . .	27

Part Three

Functions of Technicians

XIV. Technicians and their Occupations . . . . .	29
(a) General remarks . . . . .	29
(b) Summary of a survey on the functions of technicians in industry . . . . .	29
XV. Careers and Status of Technicians . . . . .	32
(a) Professional associations . . . . .	32
(b) Earnings . . . . .	33
(c) Prospects for further education and promotion . . . . .	34

Part Four

General Information - Statistical Data

XVI. The Financial Situation . . . . .	35
(a) Economic Development - National Income . . . . .	35
(b) Foreign trade . . . . .	36
(c) Expenditure for Education . . . . .	36
XVII. Educational Statistics . . . . .	42
(a) Enrolments and output. . . . .	42
(b) School buildings . . . . .	42
(c) Drop-out from technical and vocational courses . . . . .	42
XVIII. Population and Manpower Statistics . . . . .	49
(a) Population . . . . .	49
(b) Forecast of employment . . . . .	49
(c) Supply and requirements . . . . .	49
(d) Educational structure of the labour force . . . . .	49

Appendices

I. Main Types of Schools and Courses within the Educational System . . . . .	59
II. The Educational System - Technical and Vocational Schools. . .	62
III. Polytechnical Education in Yugoslavia . . . . .	63
IV. Lower-level Technician Courses	
1. Nature and number of main courses available . . . . .	67
2. Examples of alternative training methods . . . . .	68
3. Selected timetables . . . . .	70
V. Upper-level Technician Courses	
1. Nature and number of main courses offered by Higher Technical Schools . . . . .	74
2. Selected timetables . . . . .	75
VI. Skilled-Worker Courses	
1. Metal trades - machine construction . . . . .	78
2. Electrotechnology . . . . .	79
VII. Selected Bibliography . . . . .	80
VIII. List of Individuals and Organisations Consulted . . . . .	81
IX. Conclusions of the Confrontation Meetings	
A. Confrontation Meeting between the Netherlands - Spain - Switzerland and Yugoslavia . . . . .	83

B. Confrontation Meeting between Canada and Denmark . . . .	86
---	----

Tables

1. Percentage breakdown of teaching staff by qualification and type of education. (Primary and Secondary Level, 1963) . . . . .	23
2. Number of teachers, and pupil/teacher ratios (1963) . . . . .	24
3. Manpower structure in the electronic measuring instrument manufacture (percentages) . . . . .	30
4. Average earnings by category of worker in the Prvomajska Metal Works, Zagreb . . . . .	33
5. Breakdown of Gross National Product by Sector Average Annual Growth Rates (1947-1960) . . . . .	37
6. National Income (at current prices) - Purchasing power of the dinar . . . . .	38
7. Living Standards . . . . .	38
8. Balance of trade 1958-1964 (in million dinars) . . . . .	39
9. Foreign Trade - Main exports and imports . . . . .	39
10. National Income and expenditure on education 1956-64 (in current prices) . . . . .	40
11. Sources of current expenditure for education (in percentage). . . .	40
12. Expenditure by level and type of education (1963) . . . . .	41
13. Enrolments for each level of education and percentage change (Schools years 1956/57 - 1963/64) . . . . .	43
14. Enrolments for each level of education as a percentage of total enrolments. (School years 1956/57 - 1963/64) . . . . .	44
15. Part-time enrolments in higher education institutions (1951/52 - 1963/64) . . . . .	44
16. Enrolments in main secondary technical and vocational courses (1956/57 - 1962/63) . . . . .	45
17. Secondary and higher technical courses. Enrolments and output by specialisation (1956/57 - 1962/63) . . . . .	46
18. Number and types of schools (1938/39 - 1962/63) . . . . .	47
19. Dropouts from secondary technical and vocational courses (school years 1956/57 - 1960/61) . . . . .	48
20. Total Population (1931-1963, actual. 1964 -1975, estimated) . . .	50
21. Distribution of active population by economic activity 1961 (in thousands) . . . . .	50

22. Percentage distribution of Manpower, 1953, 1961 . . . . .	51
23. Breakdown of the active population by socialised and private sectors 1953-1961 . . . . .	51
24. Employment in the socialised sector by economic activity, and occupational class, 1961 . . . . .	52
25. Estimated employment in the socialised sector by economic activity and occupational class, 1970 (in thousands) . . . . .	53
26. Supply of requirements for personnel with secondary and higher qualifications - 1960-1975 (in thousands) . . . . .	54
27. Estimated needs in technical and scientific manpower. Inflow from the educational system 1961 - 1970 . . . . .	55
28. Qualification structure of the labour force in 1960 and 1975 . . . . .	56



## PREFACE

The OECD Committee for Scientific and Technical Personnel has given considerable attention to the question of technician shortage which is a key problem in the economic development of Member countries, and has on several occasions drawn attention to the need for an adequate supply of and proper training for skills at this level.

To clarify the situation as far as possible and to establish a solid base for discussion, the Committee has instituted a series of surveys in Member countries describing and analysing training conditions.

The material obtained is classified according to a standard pattern throughout, so that comparisons can be drawn between countries. The completed surveys were used as basic working documents for "Confrontation Meetings" between two or more countries. These meetings were held under a neutral chairman and were attended by teams of specialists from the participating countries. Delegates discussed each other's training systems and the various problems which arise and endeavoured to reach conclusions on questions of policy and to find solutions to technical difficulties.

The present publication, the seventh of a series, is a revised version of the working document used at the confrontation meeting between the Netherlands, Spain, Switzerland and Yugoslavia, held in Paris in December, 1965. The conclusions of this meeting, and of the previous one between Canada and Denmark, are given in Appendix IX.

The report was prepared by the OECD Secretariat, Mr. S. Syrimis, Consultant to the Directorate for Scientific Affairs, being responsible. It incorporates information already available at OECD, and in particular in the original survey carried out by a joint FEANI/EUSEC (1) Committee, supplemented by on-the-spot investigation.

---

(1) European Federation of National Associations of Engineers (FEANI). Conference of Engineering societies of Western Europe and the United States of America (EUSEC).

## Part One

### THE STRUCTURE OF THE EDUCATIONAL SYSTEM

#### I. General Data - The Place of Technical Education in the Educational System

1. The Federal Peoples' Republic of Yugoslavia consists of six Peoples' Republics: Serbia, Croatia, Bosnia, Macedonia, Montenegro and Slovenia. There are five nationalities within the Federation and nine minority groups; three languages are spoken (Serbo-Croat, Slovene and Macedonian) and two alphabets are used, Latin and Cyrillic. The four levels of government in diminishing order of authority are: Federal, Republican, District and Communal. Since 1953, regional governments have had a large measure of authority in economic and educational fields.

2. The educational system in pre-war Yugoslavia was insufficient and uneven. According to data supplied by UNESCO, in 1950 45.2 per cent of the entire Yugoslav population over 10 years old was illiterate; in some parts of the country e.g. Bosnia, Herzegovina and Macedonia, this percentage exceeded 70. During the second world war (1941-1945) the school system suffered enormous material damage. In spite of rapid reconstruction and expansion during the first ten post-war years, the shortcomings of the inherited educational system, which was not fully adapted to the requirements of the new Yugoslav society, still needed substantial reform. In June 1958, the Federal Peoples' Assembly promulgated the first "Educational Reform Act", based on a report prepared by a special committee appointed in 1954. This Act was followed by the "Special Federal Bill on Financing the School System" (1959), and the "Resolution on Training Vocational Personnel". These four documents constitute the basis of the present educational system, the main characteristics of which are:

- (i) Unified eight years compulsory primary schooling (7 to 15) followed by two to four years of secondary education (general, technical, vocational) and two to five years of higher education. The principal courses available are briefly described in Appendix I, page 59.

- (ii) Ample provision for lateral and vertical movement along the educational ladder;
- (iii) Easy access to higher education from all secondary streams;
- (iv) Ample opportunities for adult education at all levels and fields;
- (v) Social self-government and financing; schools and other educational institutions legally acquire the status of social institutions, which carries the right of selfmanagement (para. 20). The school boards, assisted by the teachers' council and the pupils' associations, deal with all educational, social and financial problems.

3. The introduction of an additional two-year cycle following compulsory schooling, and substituting to some extent the present secondary cycle, is now at an advanced stage of experimentation. The main purpose of this future reform, called "polytechnical education", will be the further unification of education and the provision of additional opportunities for better educational orientation and vocational guidance. Further details on this important innovation may be found in Appendix III.

4. During the past few years, the expansion of the Yugoslav educational system has been enormous. Though eight-year compulsory education was instituted only in 1955, enrolments in 1960 amounted to 94 per cent of the 8 - 11 age group and to 70 per cent of the 12 - 15 group; the number of pupils in secondary technical education doubled between 1952 and 1960, and the percentage of the age group in higher education increased from 2.6 to 3.5. However, according to the MRP (1) and the "Country Review" reports there are still some negative features such as: (i) serious lack of buildings, equipment and teaching staff; (ii) an expansion of the numbers in higher education without an equivalent expansion in secondary education; (iii) a tendency for secondary technical school graduates to enter university faculties, in many cases other than scientific or technical, instead of entering industry as middle-level technicians for which there is an urgent need.

5. The Yugoslav authorities have taken particular interest in the development of technical and vocational education, especially during the past few years. Rapid economic development and the intensive use of a vast network of public services organised on modern principles demanded special efforts in solving problems of trained staff. The "Resolution on the Education of Technical Personnel" adopted in 1960 provided for a well-rounded system of technical education adapted to the needs of modern technology, and fully integrated into the general system of education as illustrated in a simplified form in Appendix II. The basic principles on which the "1960 Resolution" was based are as follows:

- (i) The primary task of professional training, as a composite part of the whole system of education is to produce proficient persons for tasks in society. Practical work and specific technical and theoretical knowledge of natural sciences and social economy, indispensable for a successful vocation, should therefore be the essence of professional training.

---

(1) The Mediterranean Regional Project. Education for Economic and Social Development. Yugoslavia.

- (ii) As a result of the ever-growing application of science and technology in production and the public services, and the growing importance of the role of the workers in the process of production and in furthering socialist democracy, both the general knowledge and culture of the working people should be constantly improved.
- (iii) All institutions for technical training should tend to satisfy as fully as possible the requirements of the economy and public services. Therefore, the organization of such institutions, and the curricula and duration of training, should be adapted to the specific needs of the various economic organizations and public services for which such workers are trained.
- (iv) For the most effective solution to the problem of skilled labour, all institutions providing vocational training should combine theory with practice and make full use of the latest discoveries of science and technology. Productive work should always be a composite part of the process of education.
- (v) All institutions for vocational training for young people should give their attention to the problem of adult training also. This will eventually lead to a merging of the present school and out-of-school systems of vocational training into one single system.
- (vi) All institutions concerned with technical education, including the university, should cooperate with economic organizations and public services to improve the proficiency of personnel by such means as "studying the latest scientific and technical achievements and their application and providing students and those who decide to continue their studies with the knowledge required for specific jobs and processes."

## II. Vocational Orientation and Guidance

6. Educational and vocational orientation and guidance is not yet organised as a regular school service. In towns, "Centres of Vocational Guidance" exist in the form of services attached to the "Republic Employment Offices", which have some connection with the schools, particularly at primary level. Their main activities consist in: (i) giving advice and guidance to individuals on the basis of psychological tests; schools normally seek such advice in difficult cases only; (ii) organising short courses and seminars on vocational orientation and guidance for the teachers concerned; (iii) supplying information on training courses and employment possibilities; (iv) assisting unemployed persons to find work by supplying information on job opportunities and training and re-training possibilities.

7. In schools, the orientation process is normally limited to the so-called "extra curricula" activities and other practical work (para 10/11), organised visits to factories or work in industry, lectures and film shows, and information supplied during normal classwork. Some primary schools have a specially trained (by means of short courses etc.) staff member in charge of such activities who acts at the same time as a link between the school and the vocational guidance centre. Bigger schools have "vocational guidance boards" composed of teachers, parents and other





community members. At Federal level there are two commissions for the development of research in medicine and psychology respectively. A "Federal Bureau of Employment" is now in the process of being set up.

8. "The Yugoslav Association of Vocational Guidance" is another source of information on matters related to vocational orientation and guidance. It was established ten years ago, and today has over 5,000 members. Its main objective is to promote vocational orientation and guidance at all levels and in all fields.

9. Technical subjects combined with practical work constitute an integral part of the curriculum of primary and general secondary schools. The main objective is to give the pupils the opportunity to develop their practical skills, to orientate them towards technical courses or jobs and to facilitate the transition from school to work.

10. In primary schools, practical activities consist of:

- (i) Two hours per week of "technical education", i. e. the general basic principles of applied technology and handicrafts; the teaching of natural sciences, in the upper classes (5th to 8th) is normally combined with laboratory work.
- (ii) Organised "extra-curricula" activities in a variety of subjects such as farming, printing, bookbinding, woodwork etc. depending on the particular interest of pupils, the nature of the community (industrial, agricultural) and the school's financial possibilities. Such activities are in many cases combined with productive work.

11. In gymnasia, "technical instruction" is part of the normal curriculum and may be taught for as much as two hours per week. It includes the principles of: building construction, machine construction, electrotechnology and electronics. Direct contact with working life is achieved through actual work in industry or the civil service for a period of two months during the four years at school (two weeks each year).

### III. Authorities in Charge of Education - Co-ordinating and Planning Mechanisms

12. The Federal government has limited jurisdiction over education; it is responsible only for the main guide lines of educational policy, giving financial assistance to the comparatively underdeveloped regions, and, since 1958, contributing 50 per cent of the building costs of new universities and faculties. The responsible body is the "Federal Secretariat for Education and Culture" and several "institutes" and "commissions" such as the "Yugoslav Institute for Educational Research", the "School Buildings' Commission" etc. which assist in co-ordinating and standardising regional activities.

13. The governments of the Republics are responsible for setting the standards of the curricula in their secondary schools and in financing their higher education institutions, apart from the contribution mentioned above, from the Federal

government. In each Republic there is a "Secretariat for Education and Culture" with "Institutes of Education (primary, secondary) attached. These institutes act in an advisory capacity to the Secretariat, and also have a supervisory role.

14. The authorities in the Communes are responsible for establishing and financing their primary and secondary schools. Educational activities of every type, e. g. general, technical, commercial, agricultural, etc. all come under the same authorities.

15. Educational planning is decentralised, but the Mediterranean Regional Project office in Zagreb, which is a special service under the Federal Secretariat for Education and Culture, is doing an excellent job collecting and analysing available data. Plans for the expansion of secondary and higher education are based on manpower needs, which are determined by direct enquiries and by comparison with other countries at a similar stage of development.

## Part Two

### TRAINING OF TECHNICIANS AND OTHER TECHNICAL MANPOWER

#### IV. Definition and Grading of the Technician - Standardized Qualifications

16. In Yugoslavia the term "technician" is used to define graduates of secondary technical schools (Appendix I, page 59) while graduates of higher technical schools are classified as "engineers", and university degree holders as "diploma engineers". It is evident that the term "technician" covers the lower technician level while the term "engineer" corresponds to the upper technician level. Both lower and upper-level technicians are organised in the "Union of Technicians and Engineers", which has at present over 40,000 members.

17. Provincial autonomy in education results in considerable differences in technician programmes and in level of skill standards as may be gathered from (a) and (b) below:

#### (a) Content of courses

18. Syllabuses for secondary and higher technical schools are prepared by the schools themselves in collaboration with industry and in accordance with basic directives issued by the Secretariats for Education and Culture of their Republic, within the federal framework (para. 12). Even though each syllabus has to be finally approved by the Secretariat of the Republic concerned, they differ considerably from one school to another even of the same type, as each is specially adapted to the needs of the individual industry or industries for which it has been prepared. In some cases several schools of the same type collaborate in preparing a common syllabus.

(b) Final examinations - diplomas and certificates

19. Final examinations at all levels are organised and held by the schools in accordance with basic directives issued by the Secretariats of the respective Republics. In secondary technical and vocational schools, observers from the Secretariat, the Commune authorities and industry may be invited. Diplomas and certificates are issued by the individual schools.

V. Lower-level Technician Courses within the Formal Educational System

20. In Yugoslavia, lower-level technicians constitute a substantial part of the technician force, and their training has reached an advanced stage of development. A great variety of courses covering the industrial, mining, building, agricultural commercial, and administrative fields are now available as indicated in Appendix IV page 67.

21. Training at this level is carried out by the secondary technical schools which, in 1962, numbered 125 for industrial and 47 for agricultural trades. Industrial enterprises play an important part in supplementing the formal educational system in the training of technical manpower. Many of them have set up and operate "School Centres" consisting of training units attached to the enterprise to educate and train technical personnel at several levels (paras. 49-51).

22. Technical schools, as well as other educational institutions have the legal status, based on the principles of self-management, of sovereign social institutions. This status confers the right of self-management on the Communities, particularly for vocational questions, which means full responsibility for carrying out educational as well as other special tasks. In addition to teachers, representatives from the different social organizations also sit on the various school committees and thus ensure both general and continued aid. These representatives are delegated by the people, by social and professional organizations and by industry, or are elected by the Assemblies of Socio-Political Communities, ranging from the Commune to the Republic, depending on the kind and importance of the school. Self-management on the part of the schools has meant that all Assemblies, from the Commune to the Federation, as well as social, political, professional and industrial organizations have become intensively occupied in the country's educational questions.

23. In theory, lower-level technician courses should last four years, although in practice the length varies according to the type of course, the trade and the school concerned; much will depend on the individual needs of the industry or industries with which the school is connected; even in the same school and for the same trade several alternatives may sometimes be offered (see Appendix IV, page 67 for further details). Entrance requirements to the normal four-year courses are eight years of primary schooling (compulsory period). Where the number of applicants exceeds the number of places available, selection is normally based on the primary school marks in mother tongue, mathematics and physics; certain schools also hold entrance examinations in mathematics.



24. Curricula comprise general cultural subjects, mathematical and scientific disciplines, technical knowledge and workshop practice as indicated in Appendix IV, 3 (selected time-tables). Practical work is normally combined with actual work in industry on the basis of one month per year of schooling. However, in the normal four-year courses emphasis is usually placed on technological knowledge rather than on practical work; in some cases this appears to be a point of dissension between schools and industry, the latter preferring more intensive practical training and specialisation. Alternative ways of training provided by the schools have frequently been introduced to satisfy this demand on the part of industry. It is also expected that the "polytechnical education" period (Appendix III) will allow for more intensive specialisation on a broader base. Certain industries have shown particular interest and contribute financially to experimental work in this field.

25. Final examinations in secondary technical schools are organised by the schools themselves and comprise oral and written tests. Certain schools also require practical tests or the preparation of a complete practical and theoretical study of a specific technical project. Successful candidates are awarded a diploma which qualifies them as "technicians", which is considered equivalent to a full secondary education certificate.

## VI. Upper-level Technician Courses within the "Formal" Educational System

26. Upper-level technician courses are held by the "Two-year post-secondary schools". In 1962 there were 51 such schools covering 13 main fields as indicated in Appendix V, page 74.

27. The structural reform of technical education in 1960 led to the absorption of the majority of the two-year post-secondary schools into the first university cycle. This cycle is less specialised, however, than the training previously provided for upper-level technicians, and there is a danger that in future they will be inadequately equipped to perform their important practical tasks in industry. Furthermore, there is now a possibility that the training of an upper-level technician will be looked upon more as a stepping stone to the second university cycle than as preparation for an indispensable industrial function (1).

28. The normal length of an upper-level technician course is two years, with the exception of graphic art courses, which last three years. For admission, preference is given to lower-level technicians and highly skilled workers, normally on the basis of selective entry examinations in mathematics, physics, chemistry and, in certain cases, in the student's mother tongue. Skilled workers are accepted if they have had three years vocational training following compulsory schooling, or two years of training following two years' secondary education. Candidates who do not fulfil the above conditions may also be accepted after a minimum of four years' industrial experience in the field they wish to study.

---

(1) Country Review, Yugoslavia (OECD, 1962).

29. Curricula of the higher technical schools are prepared by the schools' Staff, usually in collaboration with industry; they therefore vary considerably from school to school and from industry to industry but all contain general subjects, mathematical and scientific disciplines, and technological subjects as indicated in the examples of selected timetables in Appendix IV, 3 page 70. Practical work is generally limited except when the schools are directly attached to big enterprises. The syllabus is then fully adapted to the needs of the individual industry and may differ in duration, pattern and content from courses of the same level held by other schools (Appendix IV).

30. Final examinations in higher technical schools are organised by the schools themselves and lead to the title of engineer which corresponds to upper-technician level. Graduates are eligible for the second cycle of the corresponding university faculty although, in certain cases, only after passing additional examinations.

## VII. Vocational Courses at Craftsman Level within the Educational System

31. Vocational courses at craftsman level are held by the vocational schools for skilled workers and "schools for highly skilled workers". The vocational schools for skilled workers are of two types as follows:

### (a) Schools for practical training

32. These provide full-time practical and theoretical training in industry and mining, building and construction, transport and communications, agriculture and forestry, commerce, hotel and catering, handicrafts, health services and medical practice. Requirements for admission are full primary education and physical ability to exercise the job chosen. Length of training varies from two to four years, depending on the trade, but in the majority of cases is three years. The curriculum comprises general cultural subjects, science and mathematics, practical training and related theory as outlined in the examples of Appendix VI, page 78. Practical training is carried out in the workshops of the school and is supplemented by actual placement in industry during vacation periods. The final examinations comprise oral, written and practical tests and lead to the skilled worker certificate. Special committees, usually composed of specialist teachers, representatives of students and delegates from industry and the educational authorities of the republic, assess the results.

Many schools for practical training are attached to individual industries as a composite part of the "school centres" (paras. 49-51).

### (b) Apprenticeship schools

33. These are part-time schools for apprentices, leading to the skilled worker certificate.

Conditions for admission, length and content of courses are similar to those for the practical training schools but the practical part of the syllabus is carried out in enterprises and amounts to approximately 50 per cent of the total training period.

Trainees receive monthly remuneration from the enterprises or from the employer if working in the private sector.

Courses for skilled workers constitute, in certain cases, the basis for technician training, as indicated in Appendix IV, page 67.

The skilled worker certificate is not considered to be equivalent to a full secondary education certificate although skilled workers may be admitted to higher technical schools and university faculties under certain conditions (paras. 28 and 39).

34. Schools for highly skilled workers provide further specialised training for skilled workers with at least two years of industrial experience and not more than 25 years of age.

The courses usually last three years, but for certain trades are as short as six months; they cover: industrial trades, building and construction, transport and communications, commerce and hotel and catering. Final examinations comprise oral, written and practical tests and lead to the highly skilled worker certificate which opens the way to higher technical training.

#### VIII. Technical Courses at University Level

35. Technical courses at university level are held by the schools of higher learning and the technical faculties.

36. The schools of higher learning offer highly specialised professional training in the technological field, agriculture, administration, physical culture and political science. At present, there are four technical schools of higher learning; these specialise in production engineering, mechanical construction and metallurgy, and in agronomy.

Requirements for admission are full secondary education and the passing of an entrance examination. Candidates without full secondary education but with actual working experience of four to five years are normally allowed to sit for the examinations.

The course lasts three to four years and leads to a diploma equivalent to a university degree which qualifies holders as diploma engineers.

37. The technical faculties are attached to the six universities of Belgrade, Zagreb, Novi Sad, Ljubljana, Sarajevo and Skopje.

There are 39 such faculties at present in mechanical engineering, electrical engineering, chemical engineering, naval engineering, architecture, civil engineering, mining and geology, metallurgy, oil technology, transport and communication, agronomy and forestry.

38. Most of the technical faculties have divided their syllabuses into three self-contained parts; the first lasts two years and leads to the certificate of engineering which corresponds to the upper-technician level (para. 27); the second leads to a university degree (engineer level) and also lasts two years; the third consists of post-graduate work and lasts from one to two years.

39. Admission to the first part is by entrance examination, preference being given to those who completed secondary education with excellent marks. Candidates

with insufficient educational qualification but with actual working experience are allowed to sit for the examination. Admission to the second part is open to graduates of the first part and of higher technical schools, but post-graduate studies are open only to graduates of the second part.

## IX. Technical Teaching Staff

### (a) Recruitment - pupil/teacher ratios

40. Teachers for skilled-worker schools and secondary technical schools are recruited mainly among university graduates and the technician force, as shown in Table 1 on page 23, giving the qualification structure of the teaching force by type of education. The table shows that in all types of educational establishments there is a small proportion of teachers with primary education only; at secondary level, there is a high proportion of teachers without higher-level qualifications.

41. Participation of women in education is unusually high, particularly at secondary level, where it reaches 32.2 per cent for secondary technical schools, and 46.1 per cent for gymnasia.

42. During the past few years the increase in the number of teachers has not kept pace with that in the number of pupils, except at primary level, however the pupil/teacher ratios still appear to be satisfactory, particularly at secondary and higher levels, although in technical vocational schools there is a high proportion of part-time teachers (Table 2, page 24).

### (b) Training courses for technical teachers

43. The educational authorities of the republics and districts organise short pedagogical courses for teachers without professional qualifications. Although these courses are not compulsory, enrolment is high as they are preparatory to the special examination held by the republics and which every teacher has to pass within three or four years of the date of his first appointment.

### (c) Status and salaries of technical teachers

44. The teaching profession in Yugoslavia enjoys a high reputation and brings teachers into direct contact with the authorities of the communes and republics, as well as with various industrial, commercial and other organizations (para 22).

45. Teachers' salaries vary considerably from school to school as a result of the system of self-management practised by the schools. Much will depend on the financial resources of the individual school and on the quantity and quality of the work offered by the teacher and which is evaluated by special committees. In general, the average income of a teacher with technical qualifications compares favourably with that of a person with equivalent qualifications in industry.



Table 1

Percentage breakdown of teaching staff by qualification  
and type of education

(Primary and Secondary level, 1963)

Type of school	Graduates of:							
	Total number of teachers	Primary school	Schools for skilled and highly skilled workers	Secondary technical and vocational schools	Gymnasia	Teacher training colleges	Two-year secondary courses	Universities and schools of higher learning
1. Primary schools . . . . .	93,434	2.4	0.4	1.7	6.8	63.3	17.4	5.6
2. School for skilled workers . . . . .	5,462	1.9	16.1	20.6	4.2	12.7	22.3	22.2
3. Secondary technical and vocational schools . . . . .	9,704	0.8	4.0	13.3	3.6	3.9	10.9	63.5
4. School centres . . . . .								
5. Gymnasia . . . . .	6,249	0.2	0.7	2.5	5.5	5.1	11.5	14.5
6. Teacher-training colleges and art schools . . . . .	3,318	1.6	1.3	2.1	2.7	28.0	12.7	51.6

Source: Office of the Mediterranean Regional Project, Zagreb.

Table 2

Number of teachers and pupil/teacher ratios (1963)

Type of school	No. of pupils	No. of teachers		Pupil/teacher ratios	
		Total	Full-time	Total	Full-time
1. Primary schools . . . . .	2,960,199	93,434	80,710	31.7	36.8
2. Schools for skilled workers .	90,245	5,462	3,031	16.5	29.8
3. Secondary technical & voc. schools . . . . .	132,758	9,704	5,877	13.7	22.6
4. School centres . . . . .	82,226	5,915	3,415	13.9	24.1
5. Gymnasia . . . . .	116,171	6,249	4,699	18.6	24.7
6. Teacher training colleges and art schools . . . . .	36,438	3,218	2,291	11.0	15.9
7. Other schools (Adult education centres, special schools, etc).	94,575	8,345	2,713	11.3	34.9
8. Two-year post secondary courses and schools of higher learning . . . . .	52,050	3,089	1,334	16.9	39.0
9. Universities . . . . .	107,360	5,262	3,823	20.4	28.1

Source: Office of the Mediterranean Regional Project, Zagreb.

46. Over 40 per cent of those teaching in technical and vocational education establishments have a joint educational-industrial career, as they are occupied simultaneously in both industry and education, as shown in Table 2, page 24. Although this may have certain disadvantages, it helps technical teachers maintain close and constant contact with industry and keep abreast of developments in both educational and industrial fields.

## X. Training Outside the Formal System

47. The resolution on the training of technical personnel, adopted in 1960, provides inter alia for the merging of the normal school and out-of-school systems into one single system of professional training (para. 5). The socialisation of all big industrial and commercial enterprises in addition to the self-management of the schools helped to make this possible.

### (a) Apprenticeship training

48. This is provided by the apprenticeship schools or the school centres described in paragraph 32. Training covers industrial, commercial, agricultural, hotel and catering, and handicraft subjects.

### (b) Courses held by non-governmental organizations

49. No differentiation is possible between governmental and non-governmental activities in the field of education, because of the social structure of the country. Two examples of the part played by industry in education and training are given below. The Central Council of the Confederation of Trade Unions of Yugoslavia, through its commission for education and culture, also participates actively in educational and research activities in several industrial and commercial fields.

50. The textile school centre in Zagreb is a training unit established and financed jointly by the community of Zagreb and a group of textile-industries. The centre provides training for future skilled workers, and lower and upper technicians, as shown in Appendix IV, 2 (page 68). Training at skilled-worker level is in the form of apprenticeship and consists of actual work in industry combined with day-release school attendance for two days a week for the first year of training and three days a week for the second. The centre also contains a school for dress-making and tailoring. Enrolment is roughly 2,000 trainees; technical teachers are recruited from industry but the majority of them have had special training abroad, usually in Germany or in Czechoslovakia.

51. The "Rade Koncar" electrical engineering firm in Zagreb, which employs over 8,000 persons, has established a school centre providing full-time training for future skilled workers and lower technicians (Appendix IV, 2, page 68). Two-year evening courses are held for upper-level technicians, admission requirements being a technician diploma, plus two years' industrial experience. The

centre also includes a school for economics and administration, organised along similar lines. Teaching staff is recruited from industry, and University professors are also used as part-time teachers for the upper-level courses.

(c) Adult education

52. Adult education is adequately organised and covers all fields and levels. Several schools and special centres hold primary-level courses for those who failed to complete compulsory schooling; the vast majority of technical and vocational training schools and centres also provide day-release and/or evening courses for adult training.

53. The Workers' Universities are educational and cultural centres which offer courses to help the worker improve his education, culture and professional qualifications. In each republic there is a large central unit, and smaller establishments are found in all industrial towns. The Workers' University in Zagreb (capital of Croatia) is a vast organization with over 10,000 trainees, 200 permanent teaching staff and 800 part-time instructors from industry, commerce and education.

(d) Correspondence courses

54. Correspondence courses in Yugoslavia have up to now contributed very little to technical and vocational education.

XI. Commercial Education

55. Commercial education is provided as part of the normal educational system and complies with the rules and regulations for technical and vocational training. The same applies to agricultural, hotel, catering and tourism courses.

XII. Agricultural Education

56. Agricultural courses are available only at skilled-worker, upper-level technician and university levels. Skilled-worker courses last from two to three years and lead after one or two years of practical experience to upper-level technician or university courses, which last two and five years respectively.



### XIII. Hotel, Catering and Tourism Courses

57. Hotel, catering and tourism courses at skilled worker level last three years and are held by special schools, while courses at lower technician level last four years and are normally offered by secondary commercial schools as a specialisation after the first two years. The latter cover the administration fields only. Technician courses at the upper level last two years and are held in special schools.

### Part Three

## FUNCTIONS OF TECHNICIANS

### XIV. Technicians and Their Occupations

#### (a) General remarks

58. In Yugoslavia as in other countries, engineers (upper-level technicians) are occupied in industry and the public services. In industry they are employed on development and research projects, construction and quantity surveying, sales and purchases usually under the supervision of diploma engineers. After acquiring experience, they may be promoted to production managers, heads of technical departments or administrative posts. In the public services, engineers are occupied in administration, technical services, public works and education. Some of them fill a dual function, in both industry and education (para. 46).

59. Lower-level technicians normally assist engineers and diploma engineers in their jobs, the most capable of them being promoted to supervisory posts.

#### (b) Summary of a survey on the functions of technicians in industry

60. A special survey on the functions of technicians in industry was initiated by OECD in 1963. The findings of this survey are summarised below:

##### (i) Introduction

61. The survey covered only the manufacture of electrical measuring instruments and was carried out by a group consisting of two electrical engineers,

one social psychologist and two industrial psychologists. Two enterprises were visited, and 20 formal inquiries were conducted with technicians employed in various sections of these firms.

62. (ii) Functions and positions of technicians in the firms

The firms visited also cover professional telecommunication, and the production of radio and electronic equipment and components. The manpower structure in these firms differs basically from that of firms specialising in heavy engineering such as machine construction or steel production, mainly because technological development in the field of electronics is rapid, and the quality and accuracy required are high. Present manpower structure in these firms is shown in Table 3 below, together with the structure desired by management.

Table 3

Manpower structure in the electronic measuring instrument manufacture (percentages)

	Present situation	Desirable
1. Engineers . . . . .	13	18
2. Technicians . . . . .	20	34
3. Highly skilled workers . . . . .	2	4
4. Skilled workers . . . . .	39	27
5. Clerks . . . . .	9	9
6. Unskilled workers and aux. clerks . . . . .	17	8
Total . . . . .	100	100

63. It was observed that a number of engineers are assigned to posts requiring university qualifications and, at the same time, some highly skilled workers occupy technician posts. Practically all technical personnel are employed in the development (67 per cent), production (17 per cent), and control (16 per cent) departments. In the development departments the supervision of various units and groups is carried out by "diploma engineers".

(iii) Jobs performed by technicians - Initiative and independence

64. The work is usually allocated by supervisors who, in the majority of the cases, are diploma engineers or chiefs of laboratories or development departments. Some technicians are given only long-term assignments

ranging from several weeks to a year, but the majority of them also receive short-term assignments. Technicians assign tasks to others only if they are charge-hands or if workers are assigned to them for specific projects. Technicians feel relatively free in their work since they perform their job independently and without permanent supervision. In fact, managers look for technicians to whom they can offer a period of initial training and who will then be in a position to work independently. Only a small number of technicians however take the initiative of suggesting and introducing new ideas and techniques despite the fact that the enterprises encourage experiments to develop new methods and techniques.

(iv) Evolution of the posts

65. The firms visited were not organised in the same way as when they started. They had grown from small departments established after the war as part of the domestic radio and telecommunication factories to manufacture electronic instruments for the local market; demand for such instruments was at that time limited. Today, market requirements by far exceed industrial capacity, which is limited by the lack of technical personnel and skilled manpower. Managers of both the enterprises visited state that, although the scarcity of diploma engineers is a serious problem, that of technicians is even greater. Some diploma engineers are at present frequently engaged in work requiring only technician-level knowledge. Therefore, although in principle managers assist and encourage the further education of technicians, they point out that, when more technicians become engineers, the imbalance of the manpower structure will be even greater (Table 3).

(v) Remarks on the education and training of technicians

66. Managers of both firms stated that the "secondary technical school did not and was not expected to produce technicians ready for industry." The overwhelming opinion was that technicians should obtain their specialised knowledge in electronics or other fields mainly through training in industry. The present school curriculum should be revised, however, to provide technicians with a basic technical knowledge and make them better acquainted with financial, productivity and organisational questions. More attention should also be given to practical work and laboratory experience. Present curricula are overloaded and technicians graduate without really mastering the content. Management of both firms claimed that one of the reasons why technicians have not sufficient practical knowledge is because teachers are mainly diploma engineers without industrial experience.
67. Technicians promoted from qualified workers are more useful for routine work and in development departments, especially in model making. They are better acquainted with manual work and have more experience in solving problems connected with mechanical construction, finishing processes and production.
68. According to a number of technicians, only a few of them have attended courses in enterprises; they acquire further knowledge either through their personal interest, reading books and literature available in their mother tongue, or with the assistance of senior technicians and engineers at work.

69. The interviews with the technicians employed mainly in development, and partly in testing, calibration, adjustment and control, showed that these are making progress and that their knowledge and level of education are far above the standard achieved at school.
- (vi) The social status of the technicians interviewed-personal aspirations
70. Relations between technicians and diploma engineers in both enterprises are good, contacts are satisfactory and no great differences exist. Investigation showed that there are no social barriers between technicians, engineers and workers.
71. The majority of the technicians interviewed stated that they were satisfied with their salary as compared with the salaries of the other categories employed.
72. Managers in both enterprises confirmed that initial salaries of diploma engineers are from 20 to 50 per cent higher than those of technicians. However, by the subsequent application of the principle of payment by result, this difference is reduced to 15 per cent, and there are cases where able technicians earn more than engineers with an equivalent experience.
73. It was apparent that the technicians interviewed were satisfied with their jobs, mainly because most of them have to spend a great amount of time on development work. This means they are permanently doing something new, their work is creative and, being to some extent independent, they have no wish to change their profession.
74. The following reasons were given as providing incentives for further study: (i) to achieve a good reputation and position in the enterprise; (ii) better possibility for advancement and higher pay; (iii) to acquire a higher standard of technical knowledge and consequently a better position and fuller recognition in society.
75. The living standard of the technicians interviewed as compared with other inhabitants was satisfactory. All the technicians were interested in social and political events and one-third of them were taking an active part in the workers' councils or union organizations.
76. The results of general education tests showed that among the technicians interviewed interest is of secondary importance in art but is relatively high in sports.

## XV. Careers and Status of Technicians

### (a) Professional associations

77. Lower and upper level technicians are organised under a common federal association, the "Union of Engineers and Technicians of Yugoslavia" which consists of six associations, i. e. one for each republic and 13 craft unions at federal level such as the "Union of Civil Engineers and Technicians of Yugoslavia",



the "Union of Forestry and Lumber Engineers and Technicians of Yugoslavia" etc., representing a total of over 60,000 members.

78. According to the Constitutional Act of the Union, its main objectives are: (i) to promote the social and professional status of the members; (ii) to organize scientific and other seminars and conferences at both national and international level; (iii) to publish reviews and other scientific material; (iv) to collaborate with the federal assembly and other political, social and economic organisations and institutions for the promotion of science and technology; (v) to assist, through collaboration with appropriate institutions and organisations, in raising the technical standard of skilled manpower.

(b) Earnings

79. The salaries of technicians vary considerably according to field of activity, type of job, personal ability and (for socialised organizations) the earnings of the enterprise.

80. Practical skill is in general highly appreciated by industry and is well remunerated; in the metal industry for instance, the earnings of skilled and highly skilled workers on the average compare favourably with those of lower and upper-level technicians respectively as shown in the example given in Table 4 below. In the chemical industry, the average salaries of technical manpower are nearly 30 per cent higher than those in the metal industry.

Table 4

Average earnings by category of worker in the Prvomajska Metal Works, Zagreb  
(in dinars (1) per month)

1. Semi-skilled workers. . . . .	40,144
2. Skilled workers and lower-level technician assistants . . . . .	50,960
3. Highly skilled workers and upper-level technicians . . . . .	65,936
4. Diploma engineers . . . . .	83,406

(1) 1,250 dinars = 1 U. S. dollar.

81. Productivity in industry also plays an important role in fixing the earnings of technical personnel. In Prvomajska, for instance, 10 per cent of the skilled workers earn more than the average engineer in the same firm. Further details on technicians' earnings may be found in paragraph 56, (vi) above.

(c) Prospects for further education and promotion

82. The structure of the country's educational system provides ample possibilities for further study in all fields and at all levels. Many industrial enterprises have established and now run their own school centres (para. 22) which offer, inter-alia, day-release and evening courses for further specialisation to make possible the upgrading of their technical personnel. Scholarship schemes for the university have also been adopted by several industries.

## Part Four

### GENERAL INFORMATION - STATISTICAL DATA

#### XVI. The Financial Situation

##### (a) Economic development - National income

83. While the Yugoslav economy, in common with the eastern countries, in general adopts the principle that the means of production (except agricultural small holdings) should be nationalised and the economy be planned, since 1949-50 there have been two important differences. First, the Workers' Councils elected by all the workers in each enterprise in the socialized sector have acquired extensive powers of management, both insofar as allocating the net disposable income between workers' wages and the enterprise's investment fund is concerned and also in orienting production and consequently the pattern of gross investment, whatever the source of financing. Secondly, this relative autonomy on the part of the enterprises, and the decentralisation of production and investment decisions have meant that a genuine market has been restored to a far greater degree for both end products and the production factors of capital and labour. The sovereignty of consumers has been recognised and, in more and more cases which now form the rule, the consumer's choice, through the mechanism of supply, demand and prices, is being increasingly allowed to affect investment decisions.

84. The main target for Yugoslav economic policy is industrial development, and the results obtained in this respect are remarkable. Production rose between 1953 and 1960 at an average rate of ten per cent per year for the Social Product (1). This

---

(1) Yugoslav definitions of the social product include only material goods and activities closely related to their production; the production of most services and administration are therefore excluded.



expansion has brought about substantial changes, the share of industry in the Social Product going up from 33.3 per cent in 1947 to 24.6 per cent (Table 5) with corresponding changes in employment, important new industries have been created, especially in iron and steel, electrical equipment and shipbuilding, and the proportion of industrial production in exports has risen considerably (Economic Surveys by the OECD, Yugoslavia, July 1963).

85. The National Income increased from D 1,834,000 million in 1958 to D 4,682,000 million in 1964 (Table 6), causing a considerable increase (135 per cent) in the per capita income, which in 1964 amounted to 240,000 dinars. The purchasing power of the dinar fell by 61 per cent during the same period. This rapid economic development has been accompanied by a substantial rise in the standard of living (Table 7).

#### (b) Foreign trade

86. To ensure the expansion of exports, the Yugoslav authorities made extensive use of internal measures, restricting demand and encouraging export enterprises. A high proportion of exports (about 50 per cent) is still subsidised while the liberalisation of imports is still only partial; in 1962 only approximately 20 per cent of imported goods were unrestricted. Although Yugoslavia has thus achieved a marked increase in her exports, these favourable results are not without their problems, since, to increase exports, Yugoslavia has to grant substantial credits while her own capital requirements remain immense (Economic Surveys by the OECD, Yugoslavia 1963). Imports have also increased considerably during the past few years, as illustrated in Table 8; they include food to supplement home production, raw materials, machinery and equipment and a range of manufactured products (Table 9) now in increasing demand as a result of industrialization and the rise in the standard of living.

#### (c) Expenditure for education

87. Total expenditure for education has increased considerably since 1956, and amounted to 5.73 per cent of National Income in 1964 (Table 10), which is high by international standards (1). However, in spite of this great effort the material conditions of the Yugoslav educational system are not yet satisfactory, owing to the accumulation of past shortages and the great expansion in enrolments, particularly at the higher level.

88. The changes in the system of financing education have produced corresponding changes in the share of the various authorities, as indicated in Table 11. The distribution of expenditure, by level of education, for the year 1963, is given in Table 12.

---

(1) This percentage is lower (approx. 4.6) when the National Income is calculated as in western countries (see footnote, page 35).

Table 5

Breakdown of Gross National Product by sector;  
average annual growth rates

(1947-1960)

	Structure of G. N. P.		Average annual growth rate	
	1947	1960	1947-60	1957-60
1. <u>Primary</u> . . . . .	<u>42.9</u>	<u>26.2</u>		
(i) Agriculture . . . . .	39.1	24.6	3.2	10.5
(ii) Forestry . . . . .	3.8	1.6	-	-
2. <u>Secondary</u> . . . . .	<u>43.9</u>	<u>55.6</u>		
(i) Industry . . . . .	33.3	46.2	9.5	14.2
(ii) Crafts . . . . .	4.0	5.0	8.6	-
(iii) Construction . . . . .	6.6	4.4	3.7	16.2
3. <u>Tertiary</u> . . . . .	<u>13.2</u>	<u>18.2</u>		
(i) Commerce, catering and tourism . . . . .	7.2	9.4	9.0	-
(ii) Transport . . . . .	6.0	8.8	10.1	13.3
<b>Total</b> . . . . .	<b>100.0</b>	<b>100.0</b>	<b>6.6</b>	<b>13.0</b>

Source: Country Reviews, Yugoslavia (OECD, 1963).

Table 6

National income (at current prices)  
Purchasing power of the dinar (1)

Year	National Income		Purchasing power of the dinar
	Million dinars	Index	1939 = 1,000
1958. . . . .	1,834	100.2	12,187
1960. . . . .	2,686	146.3	13,665
1961. . . . .	3,110	170	15,004
1962. . . . .	3,470	190	16,535
1963. . . . .	4,199	228	17,527
1964. . . . .	4,682	255	19,630

Source: Federal Institute for Statistics

(1) 1250 dinars = 1 US dollar.

Table 7

Living standards

1. Calories per head per day (1959/60). . . . .	2,970
2. Consumption of energy (in terms of hard coal per capita, kg 1960) .	858
3. Average monthly receipts of industrial worker 1961 (dinars). . . .	20,400
4. Number of passenger cars per 1,000 inhabitants (1962) . . . . .	5
5. Number of telephones per 1,000 inhabitants (1962) . . . . .	15
6. Number of radio sets per 1,000 inhabitants (1962) . . . . .	108

Source: Economic Surveys by the OECD, Yugoslavia (1963).

Table 8

Balance of trade 1958-1964

(in million dinars)

Year	Exports	Imports (1)	Balance
1958. . . . .	132,419	180,403	- 47,984
1960. . . . .	169,848	241,408	- 71,560
1962. . . . .	207,146	237,379	- 30,233
1963. . . . .	237,103	282,586	- 45,483
1964. . . . .	267,733	376,769	-109,036

(1) Excluding USA economic aid and agricultural surplus imports which amounted to: 25,101 million dinars in 1958, 6,508 million dinars in 1960, 23,939 million dinars in 1962, 34,400 million dinars in 1963 and 20,184 million dinars in 1964.

Source: Federal Institute for Statistics.

Table 9

Foreign Trade - Main exports and imports

EXPORTS	%	IMPORTS	%
1. Exports of goods and services as a percentage of GNP (average 1956-61). . . . .	14	1. Imports of goods and services as a percentage of GNP (average 1956-61). . . . .	18
2. Main exports (percentage of total exports in 1962)		2. Main imports (percentage of total imports in 1962)	
(i) Food, beverages and tobacco . . . . .	28	(i) Food, beverages and tobacco . . . . .	15
(ii) Machinery and transport equipment . . . . .	23	(ii) Machinery and transport equipment . . . . .	33
(iii) Raw materials (excluding fuels) . . . . .	14	(iii) Raw materials (excluding fuels) . . . . .	15
		(iv) Manufactured goods . . . . .	18

Source: Economic Surveys by the OECD, Yugoslavia (1963).

Table 10

National income and expenditure on education 1956-64  
(in current prices)

Year	National income ( '000 million dinars)	Expenditure for education		
		'000 million dinars	Index	Percentage of national income
1956. . .	1,445	37.7	100.0	2.61
1958. . .	1,834	63.3	168.1	3.45
1960. . .	2,686	91.5	242.7	3.40
1962. . .	3,474	191.4	507.9	5.51
1964. . .	4,682	268.5	712.3	5.73

Source: Federal Institute for Statistics (through MRP Office).

Table 11

Sources of current expenditure for education  
(in percentage)

	1957	1961
<u>Total</u> . . . . .	<u>100.0</u>	<u>100.0</u>
1. Communes . . . . .	67.4	76.9
2. Districts . . . . .	15.6	1.2
3. Republics . . . . .	17.0	21.9

source: Federal Secretariat for Education and Culture.

Table 12

Expenditure by level and type of education (1963)

Level & type of education	No. of pupils	Total expenditure (in million dinars) (1)	Expenditure per pupil in round figures (in dinars)
1. <u>Primary</u> . . . . .	2,960,199	94,212	31,800
2. <u>Secondary</u> . . . . .	457,838	44,114.8	96,500
(i) Gymnasia . . . . .	116,171	7,478	64,400
(ii) Secondary tech. schools. . . . .	132,758	13,436.2	101,200
(iii) Skilled worker schools . . . . .	90,245	7,096.4	78,600
(iv) School centres . . . . .	82,226	12,103	147,200
(v) Teacher-training colleges and art schools . . . . .	36,438	44,001.2	109,800
3. <u>Higher</u> . . . . .	159,410	28,836.8	181,000
(i) Two-year post secondary courses and schools of higher learning. . . . .	52,050	6,852.8	131,700
(ii) Universities . . . . .	107,360	21,984	204,800
4. <u>Other Schools</u> . . . . .	94,575	2,612.1	27,600
(Adult ed. centres, special schools, etc.)			

Source: Federal Secretariat for Education and Culture, MRP Office.

(1) 1200 dinars = 1 US dollar.

## XVII. Educational Statistics

### (a) Enrolments and output

89. The general trend in education for the period 1956-64 is summarised in Tables 13 and 14. During this period the number of the population attending school increased by well over a million. Enrolments in primary education dropped from 84.0 per cent of total enrolments in 1956 to 81.2 in 1964 and, during the same period, enrolments in secondary education rose from 10.8 per cent to 13.5 per cent of the total. A striking feature is the drift from general secondary schools (gymnasia) towards technical and vocational schools, particularly during the period 1952-60. Enrolments in the schools for skilled workers show a fairly slow increase, despite the fact that they offer the best conditions for study, e. g. monthly benefits, shorter courses and good occupational prospects.

90. The expansion in the number of enrolments in higher education has been so vast and rapid that, by comparison with other countries, it may be considered as extraordinary; at the same time, it appears to have placed the utmost strain on higher education facilities, despite the considerable programme of construction undertaken in the past few years. There is, therefore, a severe shortage of teachers and laboratory facilities (MRP Report). The number of part-time students attending higher courses has also increased considerably during the past few years (Table 15); in 1964 it amounted to about 35 per cent of the total student body.

91. Further analysis of enrolments in secondary and higher technical and vocational schools may be found together with the output of the various courses in Tables 16 and 17.

### (b) School buildings

92. The construction of school buildings has not kept pace with the opening of new schools. Despite the efforts made since 1944, a large number of buildings still house two, three or even four different schools.

In Table 18 the actual number of school buildings is given for the period 1938-1963. The continuously decreasing number of schools for skilled workers is counterbalanced by the establishment of schools for adults, including school centres, as a result of the integration of formal and informal school systems.

### (c) Drop-out from technical and vocational courses

93. The data available, although incomplete, show that the drop-out rates for secondary technical and vocational courses at technician and craftsman levels are fairly high (37.3 and 21.0 per cent respectively) and no clear trend (Table 19) appears.



Table 13

## Enrolments for each level of education and percentage change

(School years 1956/57 - 1963/64)

Level and type of education	1956/57	1960/61	1962/63	1963/64	Percentage change 1950-64
1. <u>Primary</u> . . . . .	2, 174, 672	2, 764, 369	2, 960, 199	3, 005, 659	39.4
2. <u>Secondary</u> . . . . .	279, 562	362, 540	448, 169	503, 424	80.0
(i) Gymnasia . . . . .	84, 141	79, 676	116, 171	141, 738	68.6
(ii) Secondary technical and vocational schools (1) . . . . .	52, 806	108, 023	153, 339	171, 586	225.0
(iii) Skilled workers schools (1) . . . . .	115, 899	139, 305	138, 713	153, 125	32.2
(iv) Other professional schools . . . . .	2, 062	3, 391	3, 391	3, 269	58.3
(v) Teacher-training colleges . . . . .	20, 930	27, 950	31, 912	28, 716	37.2
(vi) Art schools . . . . .	3, 734	4, 195	4, 643	4, 990	136.2
3. <u>Higher</u> . . . . .	60, 848	94, 763	106, 439	106, 624	75.4
(i) Two-year post-secondary courses . . . . .	7, 003	15, 179	21, 374	24, 808	254.2
(ii) Schools of higher learning . . . . .	280	1, 710	2, 546	3, 584	1, 176.0
(iii) Academies . . . . .	1, 254	1, 409	1, 755	1, 941	5.5
(iv) Faculties . . . . .	52, 311	76, 462	80, 764	76, 292	45.8
4. <u>Adult courses</u> . . . . .	71, 637	97, 673	95, 037	87, 881	22.6
Total . . . . .	2, 586, 719	3, 319, 342	3, 609, 844	3, 703, 588	

(1) Including students at school centres.

(2) Excluding part-time students.

Source: Federal Secretariat of Education and Culture.



Table 14

Enrolments for each level of education as a percentage of total enrolments  
(School years 1956/57 - 1963/64)

Level of education	Enrolments as a percentage of total		
	1956/57	1960/61	1963/64
1. <u>Primary</u> . . . . .	<u>84.0</u>	<u>83.5</u>	<u>81.2</u>
2. <u>Secondary</u> . . . . .	<u>10.8</u>	<u>10.9</u>	<u>13.5</u>
(i) Gymnasia . . . . .	3.7	2.4	3.8
(ii) Technical and vocational schools . .	2.0	3.3	4.6
(iii) Skilled worker schools . . . . .	4.5	4.2	4.5
(iv) Other schools . . . . .	0.6	1.0	0.6
3. <u>Higher</u> . . . . .	<u>2.4</u>	<u>2.8</u>	<u>2.9</u>
4. <u>Adult courses, special schools, etc.</u> . .	<u>2.8</u>	<u>2.9</u>	<u>2.4</u>

Table 15

Part-time enrolments in higher education institutions  
(1951/52 - 1963/64)

	1951/52	1958/59	1961/62	1963/64
<u>Total, part-time enrolments</u> . . . . .	<u>8,578</u>	<u>17,979</u>	<u>54,749</u>	<u>53,969</u>
(i) Faculties . . . . .	6,137	11,999	30,684	22,764
of which in tech. faculties . . . . .	(190)	(45)	(4,761)	(3,898)
(ii) Art academies . . . . .	58	24	34	40
(iii) Schools of higher learning . . . . .	175	10	1,005	2,595
(iv) Two-year post-secondary courses .	2,208	5,946	23,026	28,573
<u>Total, full-time enrolments</u> . . . . .	<u>46,195</u>	<u>78,911</u>	<u>103,261</u>	<u>106,624</u>

Source: Federal Secretariat of Education and Culture, MRP Office.

Table 16

Enrolments in main secondary technical and vocational courses  
(1956/57, 1962/63)

Type of course	1956/57		1962/63	
	Total enrolment	Percentage	Total	Percentage
1. <u>Total secondary.</u> . . . . .	279,562	100.0	448,169	100.0
2. <u>Total tech. and voc.</u> . . . . .	<u>52,806</u>	<u>18.9</u>	<u>153,339</u>	<u>34.2</u>
(i) Industrial and service courses . . . . .	20,164	7.2	56,952	12.7
(ii) Agricultural courses (including forestry and veterinary). . . . .	5,760	2.1	15,247	3.4
(iii) Commercial courses (Economics, administration) . . . . .	22,102	7.9	63,920	14.3
(iv) Medical courses . . . . .	4,730	1.7	17,220	3.8

Source: Federal Secretariat of Education and Culture, MRP Office.

Table 17

## Secondary and higher technical courses - Enrolments and output by specialisation

(1956/57 - 1962/63)

	1956/57		1960/61		1962/63	
	Enrolments	Output	Enrolments	Output	Enrolments	Output
1. Secondary Technical schools. . . . .	27, 879	3, 665	49, 823	8, 779	71, 393	11, 142
(i) Industrial (1). . . . .	13, 694	1, 895	25, 886	4, 188	41, 510	5, 175
(ii) Building construction and civil engineering . . . . .	4, 858	535	6, 280	1, 297	8, 309	1, 906
(iii) Mining, metallurgy and geology . . . . .	470	77	1, 019	179	1, 781	231
(iv) Transport and communication . . . . .	1, 520	287	3, 258	742	4, 713	877
(v) Agriculture . . . . .	5, 929	644	11, 369	2, 005	13, 548	
2. Higher Technical schools . . . . .	135	36	6, 037	525	9, 977	2, 243
(i) Industrial (2). . . . .	-	-	2, 852	345	5, 643	1, 389
(ii) Building construction and civil engineering . . . . .	-	-	984	-	1, 360	169
(iii) Mining . . . . .	-	-	-	-	97	10
(iv) Transports . . . . .	-	-	104	53	134	62
(v) Naval . . . . .	135	36	854	127	892	298
(vi) Agronomy . . . . .	-	-	1, 243	-	1, 851	288

(1) Comprises: Mechanical construction, electrical engineering, industrial chemistry, textiles, leather industry, wood industry, ship-building, food industry.

(2) Comprises: Mechanical engineering, electrical engineering, industrial chemistry, textiles, leather industry, wood industry.

Table 18

Number and types of schools  
(1938/39 - 1962/63)

	1938/39	1961/62	1962/63
1. <u>Primary Schools</u> . . . . .	<u>9,190</u>	<u>14,568</u>	<u>14,459</u>
2. <u>Secondary Schools</u> . . . . .	<u>1,136</u>	<u>3,066</u>	<u>2,961</u>
(i) Gymnasia . . . . .	205	275	300
(ii) Technical and vocational schools . .	53	490	513
(iii) Schools for skilled workers . . . .	766	692	642
(iv) Other vocational schools (1). . . . .	4	43	41
(v) Arts schools . . . . .	5	47	48
(vi) Teacher training colleges . . . . .	37	108	111
3. <u>Higher educational institutions</u> . . . . .	<u>26</u>	-	-
(i) Faculties . . . . .	20	-	-
(ii) Art Academies . . . . .	4	-	-
(iii) Schools of higher learning . . . . .	-	-	-
(iv) Two-year post-secondary schools . .	2	-	-

Source: Federal Institute of Statistics.

(1) Administrative and medical schools.

(2) Schools for adults, special schools and schools for supplementary education.

Table 19

Drop-outs from secondary technical and vocational courses  
(school years 1956/57 - 1960/61)

	1956/57	1957/58	1958/59	1959/60	1960/61	Total
<u>1. Secondary technical courses</u>						
(i) Initial enrolments . . . . .	21, 942	25, 574	28, 430	32, 912	41, 477	150, 335
(ii) Graduation . . . . .	13, 597	16, 431	16, 646	21, 349	26, 492	94, 515
(iii) Per cent wastage. . . . .	38. 0	35. 8	41. 4	35. 1	36. 1	37. 3
<u>2. Vocational courses (3 years)</u>						
(i) Initial enrolments . . . . .	43, 308	45, 565	50, 855	-	-	139, 708
(ii) Graduation . . . . .	33, 400	36, 455	40, 520	-	-	110, 375
(iii) Per cent wastage. . . . .	22. 9	20. 0	20. 3	-	-	21. 0

Source: Federal Secretariat for Education and Culture.

## XVIII. Population and Manpower Statistics

### (a) Population

94. The population of Yugoslavia increased by 31 per cent during the period 1931-1963 and it is estimated that the increase will reach nearly 50 per cent by 1975 (Table 20). The active population for the year 1961 was 45 per cent of total population occupied as shown in Table 21.

95. After the second world war Yugoslavia made a major effort towards her reconstruction and development. Manpower was transferred from low to high productivity sectors as shown in Table 22, and the socialised sector increased its share of total employment from 23.2 per cent in 1953 to 41.8 per cent in 1961 (Table 23).

### (b) Forecast of employment

96. It is estimated in the MRP study that employment in the socialised sector will pass from 3.5 millions in 1961 to 4.5 millions in 1970, and the occupational structure in this sector will undergo the changes indicated in Tables 24 and 25.

### (c) Supply and requirements

97. The supply and requirements for personnel with secondary and higher qualifications for the period 1960-1975 are given in Table 26. According to this projection there will be a substantial surplus from the business administration and pedagogical schools, although there would seem to be ample possibilities for these graduates to replace insufficiently qualified employees in administration, the social services, and commercial undertakings. A similar situation is apparent for universities and schools of higher learning. The most important surplus will be for economists and lawyers and the smallest for graduates from the technological faculties.

98. There is a substantial shortage of graduates from secondary-level technical schools and this shortage would be even greater than shown in the table if account were taken of the need to replace non-qualified personnel holding jobs for which technical secondary education would normally be required. (MRP Report). A further analysis of manpower requirements and supply has now been undertaken by the MRP office. A sample of the work so far completed is shown in Table 27.

### (d) Educational structure of the labour force

99. Substantial changes are expected to take place in the educational structure of the labour force during the period 1960-75. A preliminary estimate taken from the MRP study may be found in Table 28.



Table 20

Total population  
(1931-1963, actual. 1964-1975, estimated)

Year	Population (Actual)	Year	Population (estimated)
1931	14,539	1964	19,279
1938	16,057	1966	19,756
1948	15,842	1968	20,210
1958	18,018	1970	20,671
1960	18,402	1972	21,107
1962	18,837	1974	21,522
1963	19,065	1975	21,732

Source: Census data

Table 21

Distribution of active population by economic activity, 1961  
(in thousands)

Sector	Thousands	Percentage of population	Percentage of total population
1. Agriculture and forestry. . . . .	4,748	56.8	25.6
2. Manufacturing . . . . .	1,138	13.7	6.1
3. Construction . . . . .	318	3.8	1.7
4. Arts and crafts. . . . .	379	4.5	2.1
5. Transport . . . . .	250	3.0	1.3
6. Trade and catering . . . . .	310	3.7	1.7
7. Other industries . . . . .	995	12.0	5.4
8. Out of industry . . . . .	204	2.5	1.1
Total . . . . .	8,340	100.0	45.0

Total population 1961 = 18,607,000  
Persons with own income = 684,000

Source: Federal Institute for Statistics, 1961 Census.

Table 22  
Percentage Distribution of Manpower, 1953, 1961

	1953	1961
<u>Economic sectors</u>		
Agriculture . . . . .	70	56
Industry . . . . .	16	25
<u>Non-economic sectors</u>		
Services . . . . .	14	19
<b>Total . . . . .</b>	<b>100</b>	<b>100</b>

Source: MRP Report.

Table 23  
Breakdown of the active population by socialised and private sectors  
 1953-1961

Sector	1953		1961	
	Thousands	% of total	Thousands	% of total
1. <u>Socialised sector</u> . . . . .	<u>1,827</u>	<u>23.1</u>	<u>3,498</u>	<u>41.8</u>
(i) Economic sectors . . . . .	1,510	19.2	2,716	32.5
(ii) Non-economic sectors . . . . .	317	4.0	732	9.3
2. <u>Private sector</u> . . . . .	<u>5,560</u>	<u>70.7</u>	<u>4,334</u>	<u>51.8</u>
(i) Economic sectors . . . . .	5,530	70.3	4,234	51.3
(ii) The professions . . . . .	30	0.4	40	0.5
3. <u>Others</u> . . . . . (temporary unemployed etc.)	<u>480</u>	<u>6.1</u>	<u>541</u>	<u>6.4</u>
<b>Total . . . . .</b>	<b>7,867</b>	<b>100.0</b>	<b>8,375</b>	<b>100.0</b>

Source: Statistical Yearbook of Yugoslavia.

Table 24

Employment in the socialised sector by economic activity, and occupational class  
1961 (in thousands)

	Class A (1)	Class B (1)	Class C (1)	Class D (1)	Total
1. <u>Economic sector</u> . . . . .	149.0	149.3	1,945.7	282.7	2,526.6
(i) Industry and mining . . . . .	53.5	57.5	868.4	129.5	1,108.9
(ii) Agriculture, forestry and fishing . . . . .	26.4	14.3	268.7	30.0	339.5
(iii) Construction . . . . .	14.9	21.6	195.7	76.5	308.7
(iv) Transport and communications	12.7	45.5	167.9	17.5	243.4
(v) Trade . . . . .	25.3	2.6	171.9	8.6	208.4
(vi) Hotels, catering and tourism .	6.9	0.3	67.5	3.1	77.9
(vii) Arts and crafts . . . . .	9.3	7.5	205.6	17.5	239.8
2. <u>Non-economic sector</u> . . . . .	<u>200.8</u>	<u>149.4</u>	<u>620.2</u>	<u>32.5</u>	<u>1,003.2</u>
(i) Education and culture . . . . .	76.3	71.9	59.7	2.3	210.2
(ii) Other . . . . .	124.5	77.5	560.5	30.4	793.0
<b>Total</b> . . . . .	<b>349.8</b>	<b>298.7</b>	<b>2,565.9</b>	<b>315.4</b>	<b>3,527.8</b>

Source: Census data, 1961.

(1) Class A = Engineers, technical directors, managers, scientists, university professors, secondary school teachers, etc.

Class B = Technicians, nurses, foremen, marine officers, aircraft pilots, traffic controllers, primary school teachers, etc.

Class C = Skilled worker level.

Class D = Unskilled worker level.

Table 25

Estimated employment in the socialised sector by economic  
activity and occupational class, 1970  
(in thousands)

	Class A (1)	Class B (1)	Class C (1)	Class D (1)	Total
1. <u>Economic sector</u> . . . . .	315.4	472.6	2,546.7	227.3	3,561.9
(i) Industry and mining . . . . .	150.8	232.7	1,170.2	108.7	1,662.4
(ii) Agriculture, forestry and fishing . . . . .	31.8	36.7	329.8	37.9	435.8
(iii) Construction . . . . .	23.9	45.5	255.7	25.4	350.7
(iv) Transport and communications	30.5	60.0	243.9	21.3	355.7
(v) Trade . . . . .	43.2	43.2	201.0	8.8	296.2
(vi) Hotel, catering and tourism .	10.9	13.1	89.0	6.6	119.6
(vii) Arts and crafts . . . . .	24.0	41.7	257.2	18.6	341.4
2. <u>Non-economic sector</u> . . . . .	241.1	197.1	522.2	22.1	982.4
(i) Education and culture . . . . .	114.2	107.6	89.3	3.5	314.5
(ii) Other . . . . .	126.9	89.5	432.9	18.6	667.9
<b>Total</b> . . . . .	<b>556.4</b>	<b>669.6</b>	<b>3,068.9</b>	<b>249.3</b>	<b>4,544.3</b>

Source: Federal Secretariat of Education and Culture, MRP Office.

(1) Class A = Engineers, technical directors, managers, scientists, university professors, secondary school teachers, etc.

Class B = Technicians, nurses, foremen, marine officers, aircraft pilots, traffic controllers, primary school teachers, etc.

Class C = Skilled worker level.

Class D = Unskilled worker level.

Table 26

Supply of and requirements for personnel with secondary  
and higher qualifications - 1960-1975  
(in thousands)

1. Qualifications	2. Estimated require- ments	3. Total available by 1975	4. Difference (3-2)
<u>Secondary.</u> . . . . .	<u>978</u>	<u>885.9</u>	- <u>92.1</u>
(i) Gymnasia and art schools. . . . .	100	106.0	+ 6
(ii) Technical schools . . . . .	773	668.9	- 104.1
(iii) Teacher training colleges. . . . .	105	111.0	+ 6
<u>Higher schools</u> . . . . .	<u>161</u>	<u>216.5</u>	+ <u>55.5</u>
(i) Technical schools . . . . .	30.0	35.5	+ 5.5
(ii) Agricultural schools . . . . .	10.0	8.0	- 2.0
(iii) Schools for business administration, economics, social workers . . . . .	40.0	75.0	+ 35.0
(iv) Pedagogical schools . . . . .	75.0	91.3	+ 16.3
(v) Medical schools . . . . .	6.0	6.7	+ 0.7
<u>Universities.</u> . . . . .	<u>257.0</u>	<u>328.6</u>	+ <u>71.6</u>
(i) Technical faculties. . . . .	70.0	73.3	+ 3.3
(ii) Agricultural faculties . . . . .	36.0	42.4	+ 6.4
(iii) Other faculties . . . . .	151.0	212.9	+ 61.9

Source: MRP Report.

Table 27

## Estimated needs in technical and scientific manpower

## Inflow from the educational system, 1961-1970

	Occupational class (1)				Total
	A	B	C	D	
Total needs . . . . .	262, 697	358, 795	985, 138	-	1, 570, 630
Total supply . . . . .	152, 751	235, 011	465, 307	1, 525	854, 594
of which					
1. Higher level qualifications . . . . .	133, 611	33, 218	32, 245	-	199, 074
(i) Technological faculties and architecture . . . . .	26, 463	849	-	-	27, 312
(ii) Agriculture . . . . .	13, 200	44, 637	1, 158	-	18, 995
(iii) Medicine and pharmacy . . . . .	15, 330	-	-	-	15, 220
(iv) Other faculties . . . . .	46, 689	-	-	-	46, 689
(v) Art academies . . . . .	705	583	670	-	1, 958
(vi) Schools of higher learning . . . . .	2, 660	2, 198	2, 494	-	7, 352
(vii) Two-year post-secondary schools . . . . .	28, 674	24, 951	27, 923	-	81, 548
2. Secondary level qualifications					
(i) Technical and vocational schools . . . . .	8, 214	80, 401	35, 041	1, 502	125, 158
(ii) Commercial schools . . . . .	5, 068	31, 210	23, 386	-	59, 664
(iii) Agricultural schools . . . . .	1, 808	8, 180	2, 972	-	12, 960
(iv) Skilled worker schools . . . . .	2, 050	55, 570	368, 480	-	426, 100
(v) Teacher-training colleges . . . . .	2, 000	26, 432	3, 153	23	31, 608

Source: Federal Secretariat of Education and Culture. MRP Office.

(1) See footnote, page 53.



Table 28

Qualification structure of the labour force in 1960 and 1975  
(as a percentage of total labour force)

	Total		Economic sector		Non-economic sector	
	1960	1975	1960	1975	1960	1975
Total. . . . .	100.0	100.0	100.0	100.0	100.0	100.0
1. Personnel with higher qualifications . . . . .	6.4	8.2	4.0	4.8	18.0	27.3
2. Personnel with secondary qualifications. . . . .	12.8	11.4	7.8	7.5	36.4	33.2
3. Highly-skilled workers . . . . .	6.7	9.0	7.9	10.0	1.2	3.0
4. Skilled workers. . . . .	25.7	26.1	30.1	30.1	4.3	3.9
Total qualified personnel. . . . .	51.6	54.7	49.8	52.4	59.9	67.4

Source: MRP Report.

APPENDICES

## Appendix 1

### MAIN TYPES OF SCHOOLS AND COURSES WITHIN THE EDUCATIONAL SYSTEM

#### I. Primary Level

##### 1. Pre-school period

Infant education covers ages 4 to 7. Pre-school institutions may be set up by work organisations or parents, as well as by the communes. The number of such institutions is still limited (just over a thousand in 1962).

##### 2. Primary schools - compulsory schooling period

Primary school constitutes the backbone of the Yugoslav educational system and covers the compulsory eight-year period (7 to 15).

According to federal law, this school offers a general education and has the task of providing pupils with an essentially socialist attitude and modern general education; of guiding and helping them to choose their future education and training for their vocations.

Since the primary school is accepted as the minimum education required for all, the federal law prescribes that it must be uniform throughout the country. To secure this, the Educational Council of Yugoslavia was formed within the Federation and, in addition to its other tasks, has to determine the programme and instruction concepts for this level of schooling. The basis prescribed contained the minimum for the whole country in each of the various educational branches and their curricula, but permitted the republics and even the communes to add to the syllabus according to the needs of individual communities.

#### II. Secondary Level

Secondary education comprises several types of institutions all of which follow the compulsory primary school and, subject to certain conditions, open the way to higher education.

Examinations for admission are normally held only when the number of applicants exceeds that of the places available, and even then pupils who have completed their primary schooling with "excellent" marks are exempt. Lateral movement between different courses is possible through special examinations.

### 3. Gymnasia

Gymnasia are four-year secondary institutions providing for general education preparatory to entering the university. Two main lines are available: social sciences and modern languages; natural sciences and mathematics. However, as the degree of specialisation is slight and curricula do not differ very much, there are no restrictions on the type of faculty in which the student may enrol.

A third line, with emphasis on classical history, Greek and Latin, is also offered but is of minor importance as it absorbs hardly more than one per cent of the total gymnasia population.

### 4. Technical secondary schools

Technical secondary schools are four-year institutions providing training for lower-level technicians in such fields as industry, agriculture, transport and communications, commerce, medicine, etc. Graduates of technical schools are eligible to enrol in university faculties or other higher education institutions.

### 5. Vocational schools

Vocational schools provide for training at craftsman level and are of three types: (i) Schools for practical training, which offer full-time practical and theoretical training in industrial, agricultural, commercial, medical, hotel and catering, and handicraft trades, and lead to the skilled-worker certificate. (ii) Apprenticeship schools for the part-time theoretical training of industrial apprentices leading to the same skilled worker certificate. The length of the courses varies with the trade, but in most cases is three years. (iii) Schools for highly skilled workers, which may be considered as a continuation of the two types mentioned above; they provide advanced vocational courses of varying length (6 months to 3 years) mainly in industry. Highly skilled workers are granted direct access to upper-level technician courses (see 8 below) while skilled workers should have at least four years' vocational experience for admission to these courses.

### 6. Art schools

Art schools train artists, teaching staff and employees in cultural and educational institutions in such subjects as music, ballet and applied arts. The courses last four years.

### 7. Teacher-training schools

Teacher-training schools are five-year secondary institutions for training primary school teachers. Apart from the general teacher-training schools, there are a few more specialised schools for teachers in child-welfare, home economics, elementary vocational subjects and physical training.

### III. Higher Education

Admission to higher education is normally granted after the passing of an entrance examination by those who have full secondary education, actual working experience or special abilities. Higher education may be divided into three, self-contained parts as described below.

#### 8. Two-year post-secondary courses

These courses are held at the upper-technician level in several industrial and other fields. They may be regarded as complete in themselves or as replacing the first cycle of the university faculties, as graduates have access to the second cycle of the corresponding faculty.

#### 9. University faculties

University faculties are usually divided into three levels: the first corresponds to upper technician level and lasts two years (see 8 above); the second, after two years of further study, leads to the bachelor's degree, and the third consists of one to two years of post-graduate study.

#### 10. Schools of higher learning

These offer highly specialised professional training in technology, agriculture, administration, physical education and political sciences. The courses last from two to four years.

#### 11. Art academies

Art academies train persons to become highly qualified professional artists in the fields of music, fine and decorative arts. The courses last four to five years.

# THE EDUCATIONAL SYSTEM - TECHNICAL AND VOCATIONAL SCHOOLS

## Appendix II

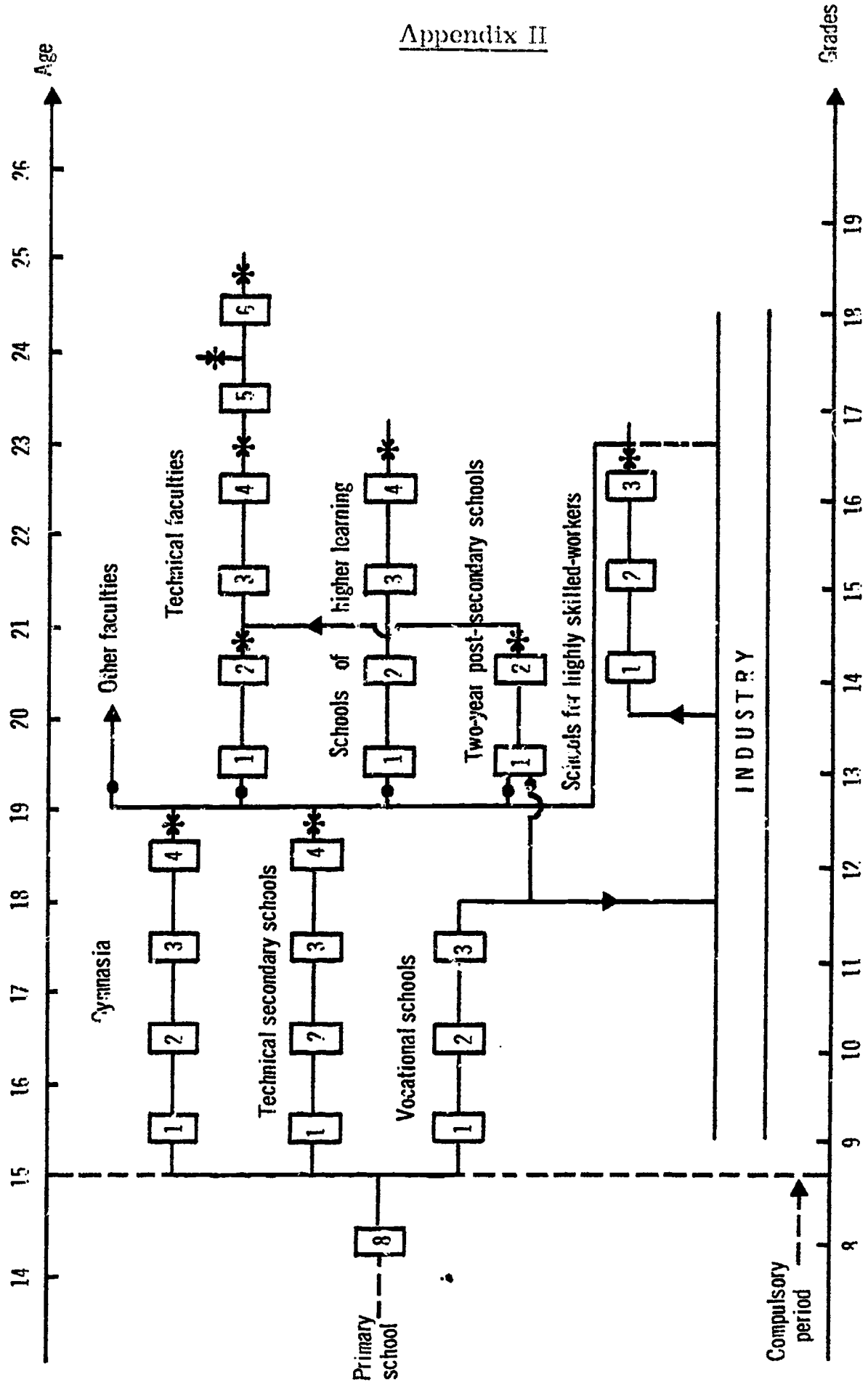

● Entrance examination \* Qualifying examination



## Appendix III

### POLYTECHNICAL EDUCATION IN YUGOSLAVIA

1. The Yugoslave Institute for Educational Research has shown particular interest in reforming the school curricula, especially at lower-secondary level. The Institute, in collaboration with university professors, associations of the institutes for the advancement of education in the republics and provinces, teachers at secondary schools and experts from industry, has proposed a draft curriculum for a new type of secondary school consisting of two lower grades (9th and 10th).

2. The proposed curriculum, for what is known as polytechnical education, has been based mainly on the experience acquired so far through experimental work in several secondary schools throughout the country, and through study and research carried out in foreign countries. Elementary school curricula have been also taken into consideration so that a proper link is maintained between the two stages of education.

3. Polytechnical education endeavours to establish a functional link between the different types of secondary education and their composite subjects, the main innovation being the introduction of technology and practical work as an integral component of the curricula at this stage, defined as: the preparatory stage of secondary education.

4. The general timetable given below shows that approximately 42 per cent of the total instruction time is devoted to general subjects, 36 per cent to scientific and technological disciplines, 17 per cent to technical work in production, the remaining 5 per cent being left for elective subjects.

#### (a) Natural sciences and mathematics

5. In this part of the programme technology is introduced as an integral part of the natural sciences. The following example, which refers to the subject chemistry with technology illustrates this.

6. The aim of the subject is (i) to supply the students with a social knowledge of elementary chemistry; (ii) to develop new scientific thinking; (iii) to enable students to grasp correctly the scientific background on which some major branches of production are based; (iv) to keep students informed on recent chemical and technological developments.

7. To achieve the establishment of a close relationship between chemistry as a science and production, a detailed study of such important items as materials, scientific basis of the processes, stages of production, typical apparatus, etc. is indispensable.

Time-table of the "preparatory phase of secondary education"

Subjects	1st year (grade 9)	2nd year (grade 10)	Instruction periods		
			Per week	Total	%
<b>1. <u>Humanities</u> . . . . .</b>	<b><u>16</u></b>	<b><u>14</u></b>	<b><u>30</u></b>	<b><u>1,050</u></b>	<b><u>41.67</u></b>
(i) Literature with elements of esthetics in language culture . . . . .	5	4	9	315	
(ii) Foreign language . . . . .	3	2	5	175	
(iii) History . . . . .	3	2	5	175	
(iv) Geography . . . . .	2	2	4	140	
(v) Socio-economic system in the SFRY . . . . .	-	2	2	70	
(vi) Physical and health education . . . . .	3	2	5	175	
<b>2. <u>Natural sciences and mathematics</u> . . . . .</b>	<b><u>12</u></b>	<b><u>14</u></b>	<b><u>26</u></b>	<b><u>910</u></b>	<b><u>36.11</u></b>
(i) Mathematics . . . . .	4	4	8	280	
(ii) Physics with elements of engineering and electro- technics . . . . .	5	5	10	310	
(iii) Chemistry with technology . . . . .	3	2	5	175	
(iv) Biology . . . . .	-	3	3	105	
<b>3. <u>Technical work in the production process</u> . . . . .</b>	<b><u>6</u></b>	<b><u>6</u></b>	<b><u>12</u></b>	<b><u>420</u></b>	<b><u>16.67</u></b>
Total compulsory trends of instruction . . . . .	34	34	68	2,380	94.45
<b>4. <u>Elective subjects</u> . . . . .</b>	<b><u>2</u></b>	<b><u>2</u></b>	<b><u>4</u></b>	<b><u>140</u></b>	<b>5.5</b>
<b>Grand Total . . . . .</b>	<b>36</b>	<b>36</b>	<b>72</b>	<b>2,520</b>	<b>100.00</b>

8. As the detailed study of a large number of processes would be difficult and unnecessary at this stage, a few basic processes should be selected and treated at length. They should be typical and include a large number of fundamental principles common to industrial chemistry as a whole. For example, the study of the production of: (i) sulphuric acid, (ii) aluminium oxide, (iii) sugar, may serve as a sound basis for the application of the above principle, as these include a number of fundamental operations such as filtering, milling, grinding, crystallisation, absorption, etc. and demand the use of a variety of typical machinery, apparatus and equipment. These processes should be studied thoroughly including the raw material, industrial location, the chemical-physical and chemical aspect, historical development, production and importance to the economy.

9. Additional subject-matter should be treated separately without a detailed description of the production process. For instance:

- The synthetic production of ammonia should be studied at length from the physical-chemical aspect; catalysis should also be studied at the same time.
- The production of soda should be used to illustrate in detail the elaboration of the chemical basis of the process, the problems of rational utilisation of by-products, and the material balance as a whole.
- When dealing with metals, floatation corrosion and preservation should be considered.
- Because of its importance petroleum should be studied in detail and reference made to the synthetic production of benzene, octane rating, cracking and petrochemical industry. The economic aspect should also be taken into consideration.

10. In order to link chemistry with its applications in other branches of industry and the economy, and with life and the students' environment in general, it is necessary, when dealing with all other products of inorganic and organic chemistry, to dwell upon the general principles of production, their application and impact on the development of civilisation and of other sciences.

(b) Education in production and technology

11. Education in production and technology is considered an indispensable component for the all-round development of the pupil because: (i) it increases work appreciation and discipline and coordinates school education with productive work; (ii) it helps broaden his understanding of the natural, economic and social sciences and the application of scientific and technological innovations; (iii) it provides an insight into the productive processes and the organization of work, (iv) it breaks down the differences between the intellectual and the young worker; (v) it provides a sound background for future intensive vocational training and education.

12. Training in production and technology, however, is never allowed to assume a professional character at this stage, the curricula being based on carefully screened and analytically elaborated integral jobs, through which the student is expected to acquire a knowledge of the basic principles of productive labour and practice in basic operations.

13. Regardless of the character of the jobs to be included in the programme, the main criterion for selecting and analysing the jobs and for the technological and practical knowledge required should be the dominance of the processes of mechanisation. It is necessary to keep a constant look out for new developments in the field of labour which might offer new opportunities for a real partnership between science and labour, and further integration between education and productivity.

14. Prior to the preparation of a formal programme in technology and production, it would be necessary to determine the technological processes and to study the organization of work in a number of local firms engaged in different activities, and also to examine the training pattern in one or more vocational schools in the area.

15. In general, five main job areas may be differentiated within the framework of technology and production; once the programme has been based on one, or on a combination of two or more of them, the following factors can be determined: (i) degree of familiarity with mechanical and manual operation and manipulations; (ii) special techniques, technical drawing, blue-print reading standards, etc.; (iii) properties, testing and use of raw materials; (iv) safety regulations and precautions; (v) socio-economic relations.

16. Based on the results of the evaluation and analysis mentioned above, the final programme for the institutes may be drawn up. This should comprise: (i) practical work, classified into two categories, namely common or fundamental, and special and (ii) related theory for both the fundamental and special aspects. Time standards should also be determined especially for particular types of workshop practice, as this directly affects the degree to which the student is expected to master the various techniques.

#### (c) Elective subjects

17. The elective part of the curricula is intended to give students an opportunity (i) to broaden and enrich the knowledge acquired in the compulsory part of the programme; (ii) to acquire new knowledge useful to their educational or occupational career. Students are not obliged to take an elective subject. The nature and content of the elective subjects are determined and elaborated by the individual schools according to the interests and aptitudes of the students and the industrial and social activities of the area.

Appendix IV

LOWER-LEVEL TECHNICIAN COURSES

1. Nature and number of main courses available

1. Mechanical engineering (machine construction) . . . . .	35
2. Electrical engineering, high power . . . . .	22
3. Electrical engineering, low power and tele-communications . . . . .	6
4. Industrial chemistry . . . . .	15
5. Textile industry . . . . .	10
6. Wood industry . . . . .	4
7. Paper industry . . . . .	1
8. Leather industry . . . . .	2
9. Food industry . . . . .	2
10. Building construction and civil engineering . . . . .	23
11. Mining, geology and metallurgy . . . . .	12
12. Internal combustion engines . . . . .	2
13. Rail transports . . . . .	7
14. Sea transports (marine engines, marine architecture) . . . . .	10
15. Agriculture and forestry . . . . .	56
Total . . . . .	<u>207</u>



## 2. Examples of alternative training methods

Apart from the normal four-year courses, several alternatives have been devised to serve the needs of particular industries. A few examples are given in the chart overleaf.

Example I shows the normal four-year courses leading to the diploma (lower technician level).

Example II shows a five-year full-time course, leading simultaneously to the skilled worker certificate and the technician diploma. This is offered by a technical school in Sisak (Croatia) which trains technicians mainly for a large local metal industry (foundries).

Example III, which shows technician training as a continuation of skilled-worker training supplemented by one year's industrial experience has been generally accepted in Croatia and is applied by all the schools there, which train technicians for the textile industry.

Example IV is an alternative to mechanical and electrical engineering technician courses. It provides for the upgrading of the skilled worker to technician without discontinuing productive work; school attendance is in the afternoon only.

Example V shows part of the full-time training scheme of a large electrical engineering firm (Rade Koncar) in Zagreb, employing over 8,000 employees. Courses are mixed (skilled-worker/technician) and last eight semesters. At the end of each semester, pupils are tested and only those considered apt are allowed to continue their training in the school. The rest enter production in any of the following grades: (i) specialised workers; (ii) independent specialised workers; (iii) semi-skilled workers; (iv) skilled workers; (v) highly skilled workers; (vi) technicians at the stages illustrated in the diagram. Special part-time courses provide an alternative way for drop-outs from the full-time school to improve their formal skills. Courses for upper-level technician training are also available and are open to holders of the technician diploma.



PATTERNS OF TRAINING

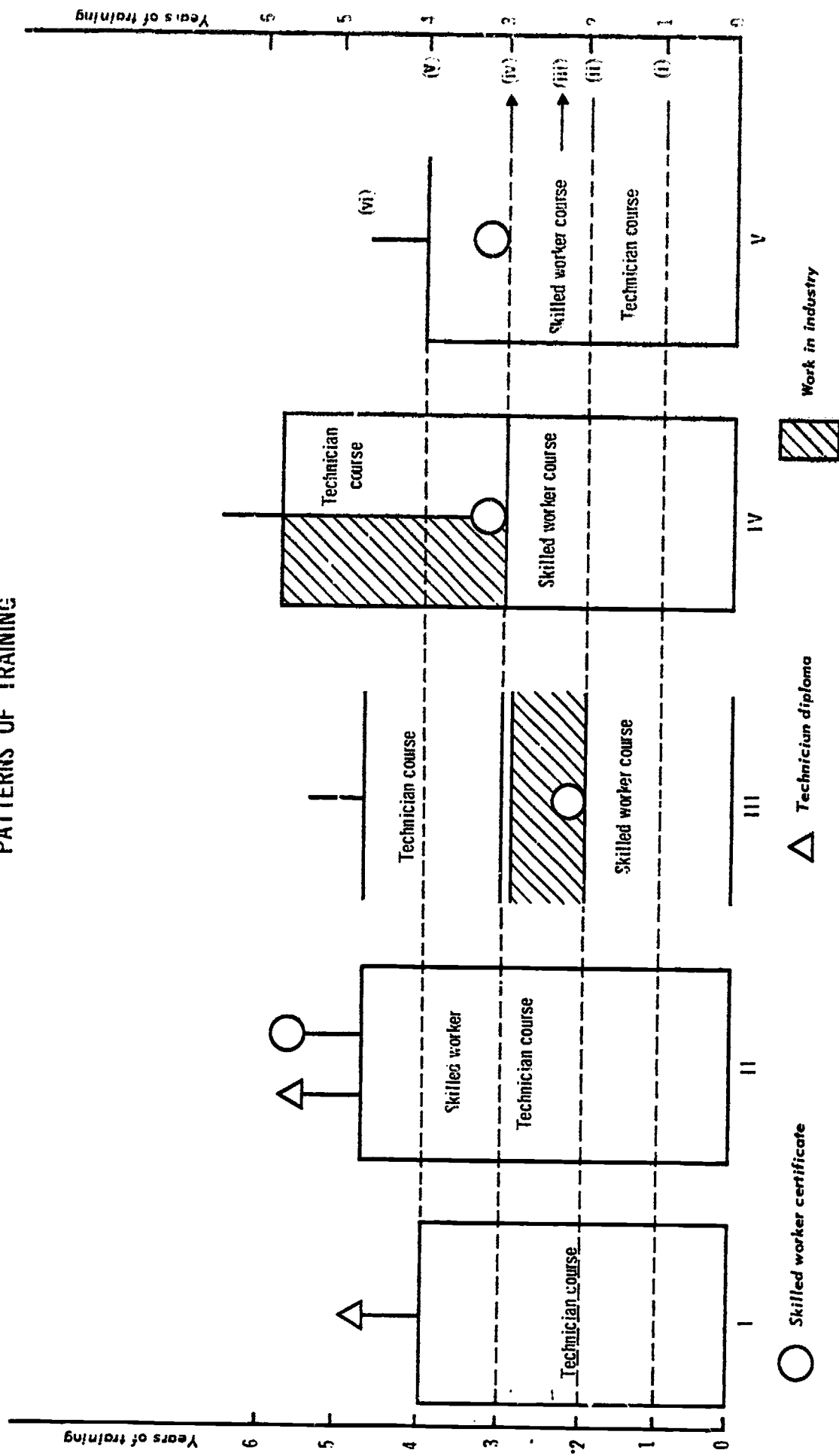

### 3. Selected time tables

#### a. Mechanical engineering course (construction)

(example from a school in Belgrade)

Subjects	Instruction periods per week					Total (1) (Units)	Percent- age
	Years						
	1	2	3	4			
<b>1. <u>General Subjects</u></b> . . . . .						<u>39</u>	24 %
(i) Mother tongue . . . . .	3	3	3	3		12	
(ii) Foreign language . . . . .	2	2	2	2		8	
(iii) History and the Constitution . . . . .	2	2	-	-		4	
(iv) Elements of political economy . . . . .	-	-	3	-		3	
(v) Physical training . . . . .	2	2	2	2		8	
(vi) Pre-military training . . . . .	-	-	2	2		4	
<b>2. <u>Science &amp; Mathematics</u></b> . . . . .						<u>25</u>	15 %
(i) Mathematics . . . . .	6	6	5	-		17	
(ii) Physics . . . . .	5	-	-	-		5	
(iii) Chemistry . . . . .	3	-	-	-		3	
<b>3. <u>Technological Subjects</u></b> . . . . .						<u>77</u>	47 %
(i) Technical & geometric drawing . . . . .	4	2	-	-		6	
(ii) Mechanics . . . . .	4	5	4	-		13	
(iii) Strength of materials . . . . .	4	-	-	-		4	
(iv) Technology of the trade . . . . .	-	6	5	7		18	
(v) Electrotechnology . . . . .	-	3	-	-		3	
(vi) Machines & machine construction . . . . .	-	3	8	8		19	
(vii) Machine tools . . . . .	-	-	-	6		6	
(viii) Encyclopedia of machines . . . . .	-	-	-	5		5	
(ix) Organization of the enterprise . . . . .	-	-	-	3		3	
<b>4. <u>Practical work</u></b> . . . . .						<u>22</u>	14 %
(i) Lab. exercise & work-shop practice . . . . .	1	2	2	6		11	
(ii) Productive work . . . . .	3	4	4	-		11	
<b>Total</b> . . . . .	<b>39</b>	<b>40</b>	<b>40</b>	<b>44</b>		<b>163</b>	

(1) 1 unit = 36 periods of instruction (approx.)

b. Mechanical engineering course (construction)  
(example from a school in Zagreb)

Subjects	Instruction periods per week					Total (1) (Units)	Percent- age
	Years						
	1	2	3	4			
<b>1. <u>General Subjects</u></b> . . . . .						<u>45</u>	24 %
(i) Mother tongue . . . . .	3	3	3	3		12	
(ii) Foreign language . . . . .	2	2	2	2		8	
(iii) History and State administration . . . . .	2	2	-	-		4	
(iv) Elements of political economy . . . . .	-	-	-	3		3	
(v) Physical training . . . . .	2	2	2	2		8	
(vi) Pre-military training . . . . .	-	-	2	2		4	
(vii) Geography . . . . .	2	2	-	-		4	
(viii) Constitution of Yugoslavia . . . . .	-	-	2	-		2	
<b>2. <u>Science &amp; Mathematics</u></b> . . . . .						<u>21</u>	12 %
(i) Mathematics . . . . .	5	5	3	2		15	
(ii) Physics . . . . .	2	2	-	-		4	
(iii) Chemistry . . . . .	2	-	-	-		2	
<b>3. <u>Technological Subjects</u></b> . . . . .						<u>79</u>	47 %
(i) Technical & geometrical drawing . . . . .	7	9	-	-		9	
(ii) Mechanics . . . . .	3	4	-	-		7	
(iii) Strength of materials . . . . .	-	3	-	-		3	
(iv) Technology of the trade . . . . .	4	4	4	4		16	
(v) Electrotechnology . . . . .	-	-	3	-		3	
(vi) Machines & machine construction . . . . .	-	5	7	4		16	
(vii) Transport . . . . .	-	-	-	2		2	
(viii) Hydraulics & hydraulic machines . . . . .	-	-	6	4		10	
(ix) Thermodynamics & internal combustion engines . . . . .	-	3	-	2		5	
(x) Organization of work . . . . .	-	-	-	3		3	
(xi) Industrial plants . . . . .	-	-	2	-		2	
(xii) Plant maintenance . . . . .	-	-	-	2		2	
(xiii) Safety precautions . . . . .	-	-	1	-		1	
<b>4. <u>Practical work</u></b> . . . . .						<u>24</u>	14 %
(i) Laboratory exercises . . . . .	3	3	3	3		12	
(ii) Workshop practice (2) . . . . .	3	3	3	3		12	
<b>Total</b> . . . . .	40	45	43	41		169	

(1) 1 unit = 36 periods of instruction (approx.)

(2) Workshop practice is supplemented by actual work in industry to the extent of one month per year of studies.

c. Electrical engineering course (high power)  
(example from a school in Belgrade)

Subjects	Instruction periods per week					Total (1) (Units)	Percent- age
	Years						
	1	2	3	4			
<u>1. General Subjects</u> . . . . .						<u>39</u>	26 %
(i) Mother tongue . . . . .	3	3	3	3		12	
(ii) Foreign language . . . . .	2	2	2	2		8	
(iii) History & State organization . . . . .	2	2	-	-		4	
(iv) Elements of political economy . . . . .	-	-	3	-		3	
(v) Physical training . . . . .	2	2	2	2		8	
(vi) Pre-military training . . . . .	-	-	2	2		4	
<u>2. Science &amp; Mathematics</u> . . . . .						<u>21</u>	14 %
(i) Mathematics . . . . .	6	5	4	-		15	
(ii) Physics . . . . .	3	-	-	-		3	
(iii) Chemistry . . . . .	3	-	-	-		3	
<u>3. Technological Subjects &amp; Workshops</u> . . . . .						<u>89</u>	60 %
(i) Technical & geometrical drawing . . . . .	5	-	-	-		5	
(ii) Mechanics . . . . .	3	3	-	-		6	
(iii) Technology of materials . . . . .	-	2	-	-		2	
(iv) Electrotechnology . . . . .	6	4	-	-		10	
(v) Elements of machines . . . . .	-	2	2	-		4	
(vi) Mechanical fitting . . . . .	3	-	-	-		3	
(vii) Electrical fitting . . . . .	-	3	-	-		3	
(viii) Electrical measurements . . . . .	-	4	5	-		9	
(ix) Electrical lighting & installations . . . . .	-	5	-	-		5	
(x) Electrical installations (general) . . . . .	-	-	4	3		7	
(xi) Electrical machines (Theory & practice) . . . . .	-	-	6	10		16	
(xii) Winding of electrical machines . . . . .	-	-	1	1		2	
(xiii) Electric power in industry & traffic . . . . .	-	-	-	3		3	
(xiv) Cable jointing . . . . .	-	-	3	3		6	
(xv) Power stations . . . . .	-	-	-	5		5	
(xvi) Organization of the enterprise . . . . .	-	-	-	3		3	
<b>Total</b> . . . . .	<b>38</b>	<b>37</b>	<b>37</b>	<b>37</b>		<b>149</b>	

(1) 1 unit = 36 periods of instruction (approx.)

d. Electrical engineering course (high power)  
(example from a school in Zagreb)

Subjects	Instruction periods per week					Total (1) (Units)	Percent- age
	Years						
	1	2	3	4			
<b>1. General Subjects</b> . . . . .						<u>43</u>	30 %
(i) Mother tongue . . . . .	3	3	3	3		12	
(ii) Foreign language . . . . .	2	2	2	2		8	
(iii) History & State administration . . . . .	2	2	-	-		4	
(iv) Elements of political economy . . . . .	-	-	-	3		3	
(v) Physical training . . . . .	2	2	2	2		8	
(vi) Pre-military training . . . . .	-	-	2	2		4	
(vii) Geography . . . . .	2	2	-	-		4	
<b>2. Science &amp; Mathematics</b> . . . . .						<u>23</u>	16 %
(i) Mathematics . . . . .	5	5	3	2		15	
(ii) Physics . . . . .	2	2	2	-		6	
(iii) Chemistry . . . . .	2	-	-	-		2	
<b>3. Technological Subjects &amp; Workshops (2)</b> . . . . .						<u>77</u>	54 %
(i) Technical & geometrical drawing . . . . .	5	-	-	-		5	
(ii) Mechanics . . . . .	2	3	-	-		5	
(iii) Technology of materials . . . . .	2	2	-	-		4	
(iv) Electrotechnology . . . . .	6	6	-	-		12	
(v) Elements of machines . . . . .	-	4	-	-		4	
(vi) Encyclopedia of machines . . . . .	-	-	4	-		4	
(vii) Electrical measurements . . . . .	-	4	4	-		8	
(viii) Electrical lighting & installations . . . . .	-	2	2	-		4	
(ix) Electrical machines . . . . .	-	-	6	7		13	
(x) Electrical network . . . . .	-	-	3	2		5	
(xi) Power stations . . . . .	-	-	-	5		5	
(xii) Automation . . . . .	-	-	-	4		4	
(xiii) Organization of work . . . . .	-	-	-	3		3	
(xiv) Safety precautions . . . . .	-	-	1	-		1	
<b>Total</b> . . . . .	<b>35</b>	<b>39</b>	<b>34</b>	<b>35</b>		<b>143</b>	

(1) 1 unit = 36 periods of instruction (approx. )

(2) Workshop practice is supplemented by work in industry for one month for each year of the course.

Appendix V

UPPER-LEVEL TECHNICIAN COURSES

1. Nature and number of main courses offered by Higher Technical Schools

	<u>No. of Courses</u>
1. Mechanical engineering (Mechanical construction, locomotives) . .	10
2. Electrical engineering . . . . .	3
3. Industrial chemistry . . . . .	4
4. Textile industry . . . . .	4
5. Leather industry - shoe manufacturing . . . . .	3
6. Food industry . . . . .	1
7. Building construction and civil engineering. . . . .	1
8. Quantity surveying . . . . .	2
9. Non-metallic constructions . . . . .	1
10. Graphic arts . . . . .	1
11. Railroad transports . . . . .	1
12. Sea-transports . . . . .	5
13. Agronomy . . . . .	10
Total . . . . .	<u>46</u>



2. Selected time-tables

a. Mechanical engineering course (construction)

(Example from a school in Novi Sad)

Subjects	Instruction periods per week				Total (1) (Units)
	Semesters				
	1	2	3	4	
1. Mathematics (algebra, analytical geometry, calculus) . . . . .	4	4	-	-	8
2. Physics . . . . .	4	4	-	-	8
3. Mechanics . . . . .	4	4	-	-	8
4. Elements of construction . . . . .	5	4	-	-	9
5. Technology of materials . . . . .	10	6	-	-	16
6. Metal treatment . . . . .	-	10	18	15	43
7. Metal construction - machine tools . . . . .	-	-	8	10	18
8. Technical control . . . . .	-	-	6	5	11
9. Industrial installations . . . . .	4	4	-	-	8
10. Production economics . . . . .	-	3	3	3	9
11. Job layout . . . . .	-	-	4	4	8
12. Workshop practice . . . . .	5	-	-	-	5
<b>Total . . . . .</b>	<b>36</b>	<b>39</b>	<b>39</b>	<b>37</b>	<b>151</b>

(1) 1 unit = 18 periods of instruction (approx.)

b. Mechanical engineering course (Locomotives)  
 (Example from a school in Belgrade)

Subjects	Instruction periods per week				Total (1) (Units)
	Semesters				
	1	2	3	4	
1. Mathematics . . . . .	6	6	-	-	12
2. Physics . . . . .	6	6	-	-	12
3. Technology of materials. . . . .	4	2	-	-	6
4. Economics and transport science. . . . .	4	-	-	-	4
5. Political economy - state economy . . . . .	4	-	-	-	4
6. Elements of statistics . . . . .	4	-	-	-	4
7. Signalling and communication installations. . . . .	-	-	8	10	18
8. Book-keeping . . . . .	-	6	-	-	6
9. Locomotives - moving parts - traction . . . . .	-	-	6	6	6
10. Rails, stations and installations . . . . .	-	-	6	6	12
11. Traffic organization . . . . .	-	4	4	4	12
12. Tariffs and tariff policy . . . . .	-	2	4	-	6
13. Foreign language . . . . .	4	4	4	4	16
<b>Total . . . . .</b>	<b>32</b>	<b>30</b>	<b>32</b>	<b>30</b>	<b>124</b>

(1) 1 unit = 18 periods of instruction (approx.)

c. Electrical engineering course

(i) Production of electrical machines

(ii) Designs of electrical machines

(Examples from a school centre in Zagreb)

Subjects	Total number of instruction periods	
	(i) Production	(ii) Design
1. Mathematics . . . . .	664	664
2. Descriptive geometry . . . . .	32	-
3. Mechanics . . . . .	172	84
4. Thermodynamics . . . . .	84	84
5. Technology of the trade . . . . .	188	204
6. Elements of machines . . . . .	84	32
7. Tools and devices . . . . .	68	-
8. Machine tools . . . . .	84	-
9. Encyclopedia of machines . . . . .	84	84
10. Organisation and economics . . . . .	52	52
11. Standardization of production . . . . .	16	16
12. Electrotechnics . . . . .	84	136
13. Induction . . . . .	-	84
14. Electrical products . . . . .	188	256
15. Electrical measurements . . . . .	-	32
16. Testing of electrical products . . . . .	-	64
17. Electrical plants . . . . .	36	36
<b>Total . . . . .</b>	<b>1, 836</b>	<b>1, 828</b>

Appendix VI

SKILLED-WORKER COURSES

Selected time-tables

1. Metal trades - machine construction

Subjects	Instruction periods per week				Total (1) (Units)	Percent- age
	Years					
	1	2	3			
1. <u>General subjects</u> . . . . .				<u>14</u>	12 %	
(i) Mother tongue . . . . .	2	2	2	6		
(ii) Civics . . . . .	-	-	2	6		
(iii) Physical training . . . . .	2	2	2	6		
2. <u>Mathematics and Science</u> . . . . .				<u>14</u>	12 %	
(i) Mathematics . . . . .	4	2	2	8		
(ii) Physics . . . . .	2	4	-	6		
3. <u>Technological subjects</u> . . . . .				<u>26</u>	22 %	
(i) Resistance of materials . . . . .	4	-	-	4		
(ii) Technical drawing . . . . .	4	2	-	6		
(iii) Technology of the trade . . . . .	-	3	3	6		
(iv) Elements of machines . . . . .	-	3	3	6		
(v) Encyclopedia of machines . . . . .	-	-	2	2		
(vi) Production economics . . . . .	-	-	2	2		
4. <u>Practical work</u> . . . . .				<u>63</u>	54 %	
Workshop practice . . . . .	21	21	21	63		
Total . . . . .	39	39	39	117	100 %	

(1) 1 unit = 30 periods of instruction (approx.)

Source : Secretariat for Education and Culture, Belgrade.

## 2. Electrotechnology

Subjects	Instruction periods per week				Total (1) (Units)	Percent- age
	Years					
	1	2	3			
<b>1. <u>General Subjects</u></b> . . . . .				<u>14</u>	11 %	
(i) Mother tongue . . . . .	2	2	2	6		
(ii) Civics . . . . .	-	-	2	2		
(iii) Physical training . . . . .	2	2	2	6		
<b>2. <u>Mathematics and Science</u></b> . . . . .				<u>14</u>	11 %	
(i) Mathematics . . . . .	4	2	2	8		
(ii) Physics . . . . .	2	4	-	6		
<b>3. <u>Technological subjects</u></b> . . . . .				<u>35</u>	28 %	
(i) Technical drawing . . . . .	4	-	-	4		
(ii) Electrotechnics . . . . .	3	3	-	6		
(iii) Knowledge of materials . . . . .	-	3	-	3		
(iv) Technology of the trade . . . . .	4	5	5	14		
(v) Electrical measurements . . . . .	-	-	3	3		
(vi) Power production and distribution . . . . .	-	-	3	3		
(vii) Production economics . . . . .	-	-	2	2		
<b>4. <u>Practical work</u></b> . . . . .				<u>63</u>	50 %	
Workshop practice . . . . .	21	21	21	63		
<b>Total</b> . . . . .	42	42	42	126	100 %	

(1) 1 unit = 30 periods of instruction (approx.)

Source : Secretariat for Education and Culture, Belgrade.

## Appendix VII

### SELECTED BIBLIOGRAPHY

1. Draft report on the education and training of engineers of non-university level and technicians in Yugoslavia, (OECD, through FLANI-Eusec, 1963).
2. Report on the inquiry into the functions of technicians in industry in Yugoslavia (OECD, DAS/ST/64.3).
3. The Mediterranean Regional Project. Education for Economic and Social Development, Yugoslavia (OECD June, 1964).
4. Economic surveys by the OECD, Yugoslavia, 1963.
5. Country Reviews, Yugoslavia (OECD, 1962).
6. Policy for school (Provisional summary of the industrial Seminar in Rescati, OECD, 1965).
7. The proposed system of education in the Federal Peoples' Republic of Yugoslavia (Commission for School Reform, Belgrade, 1959).
8. Education in Yugoslavia (Medunarodna Politika, Belgrade, 1964).
9. Vocational training in Yugoslavia (Secretariat for Education and Culture, Belgrade).
10. Curricula and Syllabi of the preparatory stage of secondary education (Draft report, Yugoslav Institute for Educational Research, Belgrade, 1966).
11. Courses for technical teachers (Institute for Technical and Vocational Education of Serbia, 1965).
12. Technical and vocational school programmes (Institute for Technical and Vocational Education of Serbia).
13. Technical and vocational school programmes (Institute for Technical and Vocational Education for Croatia).
14. Training programme of Rade Koncar school centre.
15. The enterprise and national income distribution (A. Polajnor, published by the Yugoslav Trade Unions, 1963).
16. Social self-government (Medunarodna Politika, 1965).
17. Statistical pocket-book of Yugoslavia (Federal Institute for Statistics, 1965).



Appendix VIII

LIST OF INDIVIDUALS AND ORGANISATIONS CONSULTED

1. Federal Secretariat for Education and Culture  
(Mr. V. Colic, Advisor on Technical Education.  
Mrs. Bozickovic, commission for cultural relations with foreign countries.)
2. Yugoslav Institute for Educational Research
  - (i) Technical and Vocational Education Division  
(Prof. P. Zivojinovic, Director)
  - (ii) Documentation Division
3. Institute for Technical Education of Serbia  
(Mr. Povlovic, Director)
4. Secretariat for Education and Culture of Croatia
  - (i) Institute for the Development of Primary Education  
(Mr. Muhvic, Advisor)
  - (ii) Institute for the Development of Technical and Vocational Education  
(Mrs. A. Ante, Director) (Mr. Z. Jurkovic, Deputy Director)
5. Office of the Mediterranean Regional Project  
(Mrs. S. Saric, Deputy Director)
6. Yugoslav Association for Vocational Guidance  
(Miss Brancic, Member)
7. Town Centre for Vocational Guidance, Belgrade  
(Mr. Illic, Director)
8. Schools and colleges
  - (i) Osnovna Skoka, Jordanovac 108, Zagreb (Primary School)  
(Mr. Puzevski, Director)
  - (ii) Secondary Technical and Polytechnical School, Zagreb, Klačeva 9,  
(Mrs. Antic, Director)
  - (iii) Central School of Chemistry - Proleterskih Brigade 269, Zagreb  
(Prof. Dumic, Director of the Centres. Prof. Zozko, Director of the School)

- (iv) Central School of Textiles. Lole Ribara 126, Zagreb  
(Prof. Mika, Director).
  - (v) Central School for Metal Industries  
(Dr. Dzjicva, Zagreb)  
(Mr. B. Drago, Director)
  - (vi) Rade Koncar School Centre  
(Director of two-year post-secondary schools)
  - (vii) Zagreb Central Workers' University  
(Mr. Velcic, Deputy-Director)
9. Prvomajska Metal Industries, Zagreb (Eng. Zdravko, in charge of training).
10. Central Council of the Confederation of Trade Unions of Yugoslavia, Belgrade  
(Mr. S. Bezdánov, Head of the Commission for Education and Culture)
11. Union of Engineers and Technicians of Yugoslavia, Belgrade  
(Mr. S. Nícolic, President)

## Appendix IX

### CONCLUSIONS OF THE CONFRONTATION MEETINGS

#### A: Confrontation Meeting Between The Netherlands - Spain - Switzerland - Yugoslavia

1. The discussions followed the procedure adopted in the previous confrontation meeting between Canada and Denmark, the main conclusions of which were adopted by the meeting. These conclusions are incorporated here as Part B of this Appendix for the sake of easy reference.

2. The participation of a large number of countries with different systems and methods and the availability of completed reports on these countries made the discussion extremely profitable and lively and brought to light issues which had not appeared before. A brief account of these new issues as they have been discussed under the various agenda items is given below.

##### (a) Standardised qualifications

3. It appears that an attempt to set international standards as regards technician training courses will not lead to any valid results, because of the existing great differences in structure and content of these courses in the various countries. However, it would be useful to define the minimum qualifications required for each grade so as to devise a yardstick against which one could measure and evaluate the situation in each Member country.

##### (b) The technician force

4. In most cases technician courses aim at the production of middle level technical manpower to fill in existing gaps in the rapidly developing economy. It should be emphasised, however, that in the case of countries in the process of industrialisation, availability of such a technical force might play a decisive role in the establishment of new industrial concerns and be a prerequisite to set developing industry on a sound and competitive basis.

5. When planning for technical education it is important to know, among other things, the appropriate ratio: university engineer/higher technicians. Although this ratio may vary from country to country, depending mainly on the nature of industry, it is observed that in the majority of cases, a higher technician force three times larger than the respective engineering force will be required effectively to support and supplement the latter.

6. It was observed that in all four countries under examination there was a scarcity of higher technicians. Among the reasons given for this scarcity, the following, although not always universally applicable, are worthy of note:

- (i) Inadequate supply of information to parents and prospective students, as regards technician studies and careers, due to lack of properly organised and functioning educational and vocational orientation and guidance service.
- (ii) The role of higher technicians in industry is not, in all cases, well defined and appreciated. The social and professional status of the technician is still vague and in many cases technicians are still considered as "second class" engineers.
- (iii) Promotion possibilities through further studies are, in certain cases, extremely limited. Although the vast majority of technicians are expected to enter the "economy" directly, provision should be made for those who have the ability and interest to be enabled to continue their studies for higher qualifications.
- (iv) The educational system is finding it extremely difficult to keep pace with the constantly increasing demand of a rapidly developing industry.
- (v) Lack of reliable statistical data on present and future needs in technical manpower do not permit effective planning in the educational field.

(c) Technician training courses

7. When using the term "apprenticeship" one should have in mind that it does not necessarily refer to craft training only. There are countries, such as the United Kingdom, where apprenticeship training covers the whole range of technical force from the skilled worker up to and including the university engineer.

8. Although school-training is indispensable it should be realised that it has its limitations. Therefore, training within industry should constitute an integral part of the technician training process.

9. It was agreed that there are at least two possible ways of training in order to ensure desirable adaptability of the "end-product" to the continuously changing needs of modern technology:

- (i) To give narrow and deep specialisation providing for retraining possibilities on a similar basis, as might be proposed by a special "retraining committee";
- (ii) To train on broad scientific and technical background allowing for further specialisation within industry. Special short courses on new developments and techniques may be organised by the technical colleges in collaboration with industry. It appears that the latter method of training gives better results as regards both the quality and adaptability of technical personnel and is therefore highly recommended.

10. As technology is developing at a rapid pace it does not appear feasible for the educational system to keep abreast of it. Therefore, industry is expected to react first by providing necessary training courses, which may then be adopted and further developed by the technical colleges.

(d) Co-ordination of efforts in the training process - industry participation

11. The establishment of a co-ordinating mechanism charged with policy making and all other matters related to technical education and training is considered of vital importance, no matter what the social and political structure of the country is. Such a mechanism should be composed of representatives of the educational authorities, the teaching force, other governmental and private institutions participating in the training scheme, employers' and employees' associations and industry.

12. Under Item 5 of the agenda the several forms of participation of industry in the training process were thoroughly discussed. It was agreed that active participation of industry, including jointly financed (industry/educational authorities) training programmes, is of vital importance and positively contributes to the development of technical education and training. Reference was also made to the pattern of co-operation between industry and education developed recently by the United Kingdom. (Technical training, under the Industrial Training Act, 1964).

13. Participation of industry representatives in a central co-ordinating mechanism (see under 11 above), in technical school boards and examination boards and the establishment of jointly financed (government and industry) training programmes are considered as realistic measures to secure the desirable active participation on its part.

(e) Recruitment and training of technical teachers

14. In the discussion of the problem of recruitment and training of technical teachers, it was revealed that all four countries experience much difficulty in securing in adequate numbers properly qualified personnel to cope with modern industrial and educational requirements.

15. In order to be efficient in his job, a technical teacher should possess adequate knowledge in a variety of subjects. Technical knowledge and experience should be supplemented by pedagogical training covering child and adult education, psychology of the trade, labour market problems, industrial organisation and financing, productivity, etc. Such knowledge can be acquired only through special training which should, therefore, be regarded as part and parcel of the technical teacher training process.

16. Entrants from industry to teaching, lacking pedagogical training, frequently experience great difficulty in performing teaching tasks. Often they have to learn by trial and error and the students suffer from their initial ignorance of efficient teaching methods. On the other hand, experience of certain countries shows that, as a general rule, adult personnel originating from industry are rather reluctant to readjust themselves to school conditions and be exposed to formal training.



### B. Confrontation Meeting Between Canada and Denmark

(Revised version)

#### (a) Delineation of the category of skilled labour force under consideration

1. It was agreed that a "scholastic" definition of the technician should be avoided. The force under consideration was defined as that which lies between the skilled worker at the one end and the professional engineer at the other.
2. It was decided that although discussions should be focussed on engineering technicians, as information available was mainly in this field, technicians in other fields should also be covered as adequately as possible.

#### (b) Level of Technicians - Certification - Training

3. It was agreed that the technician force should be classified in two main levels, provisionally termed the junior or lower technician level and the senior or upper technician level. The classification should be based not on functional assignments but on educational qualifications which need not necessarily be acquired in a formal way.
4. Difficulty was experienced in comparing the training programmes of the two countries because of differences in basic principles. The Danish system is mainly based on apprenticeship training while the Canadian is entirely institutional. After discussion it was agreed that though apprenticeship should not be a prerequisite for technician training a period of practical training in industry is essential. The Danish authorities have already realised this fact and are planning to reduce the apprenticeship period preceding technician training.
5. By comparing the "Teknikum Engineer" of Denmark with the "Technologist" of Canada it became evident that Senior Technician training should be a standardised post-secondary training of a less theoretical but positively more practical character than the university level training in parallel fields.
6. By studying the fields of activity of Junior technicians it was agreed that Junior technician training programmes should be flexible in character and duration, and should be particularly adapted to the needs of the individual trade in each country. A basic general education of at least 10 years was considered an essential prerequisite for the production of an adaptable "end product". This educational background, together with the additional education and training acquired through the course proper, should bring the junior technician to an educational level comparable to that of a full secondary education.  
Specific training programmes were further discussed on the basis of an illustrated exposé (projection of slides) by the Danish Delegation.
7. Standardised certification, already well ahead in Denmark, was considered essential not only at national level but also internationally. OECD was invited to assist Member countries in this respect.



(c) Vocational Guidance Service - Wastage from technical courses

8. Study of relevant information revealed that vocational guidance services in both countries are not adequately organised. It was decided that further steps should be taken to establish effective services in both the vocational guidance and the vocational selection fields.

9. Wastage from Senior Technician and University courses appeared to be a major problem, particularly in Canada. Many factors seem to influence this wastage; undoubtedly among them is the inadequate method of vocational guidance and selection.

It was decided that further investigation should be undertaken to define (i) the reasons for high wastage, (ii) what happens to the "drop-outs".

(d) Recruitment and training of technical teachers

10. In both countries recruitment of technical teachers presents difficulties because of the scarcity of properly qualified personnel and the competition from industry.

11. It was agreed that a technical teacher should:

- (i) possess qualifications ensuring thorough theoretical and practical knowledge of the subject he is expected to teach;
- (ii) have industrial experience in appropriate fields;
- (iii) be familiar with basic educational principles and possess adequate knowledge of teaching methods and techniques;
- (iv) be kept continuously aware of new developments in the educational and industrial fields.

It was agreed that to ensure this represented an important area where further governmental action was necessary, OECD was invited to assist the countries in this respect.

12. The possibility of securing part-time services of personnel from industry was discussed. It was agreed that this procedure, though difficult to put into practice, at least so far as day courses are concerned, should be further explored; in effect it encouraged the person concerned to keep continuously up to date on both the theoretical and practical sides.

13. Further discussion led to the conclusion that a reciprocal flow from industry to education and vice-versa is highly desirable. To ensure this, establishment of rules for recognition of a "continuity of service" (years of service, pension, etc.) would be necessary. In Denmark, this problem is being tackled by the technicians' professional association.

14. Discussion on the status and salaries of technical teachers revealed that authorities in charge should be advised to work out salary scales, pension allowance, etc., competing with those in industry.

(e) Authorities in charge of technical and vocational education - Co-ordination of efforts

15. Provincial autonomy in Canada creates a special situation and makes comparison with Denmark or some other European countries difficult. Discussion led to the conclusion that although a decentralisation is for several reasons advisable, the existence of a central co-ordinating authority is indispensable to ensure the requirements of sound educational policy at national level and the desirable standardisation of qualifications as a pre-requisite for interal mobility.

(f) Status of technicians and their careers

16. An examination of the information available led to the conclusion that at present two types of technicians exist in each country, i. e. :

(i) those classified as technicians by virtue of their educational qualifications;

(ii) those who, because of long experience and aptitude, perform the duties of technicians, regardless of their formal qualifications.

The latter category however was created in each case to meet the urgent requirements of the rapid industrial expansion with which the provision of educational facilities could not keep pace; this category is gradually fading out in both countries.

17. Discussion on the organisation and functions of technicians' professional associations led to the conclusion that the establishment of such associations should be encouraged, as they greatly contribute to the social recognition of the professional status of this category of skilled personnel. The successful example of Denmark should encourage other countries to proceed in the same direction.

18. Discussion on the earnings of technicians in industry revealed that these largely depend on the personal ability of the individual and in some cases are higher than those of the professional engineers.

19. The limited possibilities existing in the two countries for promotion from skilled worker to Junior Technician to Senior Technician was shown to be a feature of the present situation. However, in Denmark, it appears that Teknikum Engineers have many more opportunities as compared to their Canadian counter-parts (technologists) to undertake managerial or technical jobs, normally requiring an engineering degree in industry.

20. It is recommended that promotion from one skilled category to another through further studies be encouraged and facilitated through inter-relating the structure and content of the training programmes. However, it should always be kept in mind that training for each skilled category is an entity in itself and cannot be regarded as part of another; consequently, unnecessary distortion of training programmes for the sake of continuity and transferability should definitely be avoided.

(g) Availability of statistical data

21. In both countries the availability of statistical data enabling the planning and implementation of technician training programmes is inadequate or does not exist at all. It was decided that efforts should be made to secure such data mainly based on the real needs of industry and not on the available capacity of the educational establishments. However, one of the main difficulties in estimating the needs of industry in skilled manpower was the hesitation of industry itself to make any firm statement as regards future needs. Research and Development Services were usually found to be more reliable sources for such information.

No. 22419/October 1967